



Mumbai : 703, Centrum IT Park, Opp. Railadevi TMC Office, Wagle Estate MIDC, Thane (W) - 400604, Maharashtra
nachiket@purencure.com | sachin@purencure.com | +91 - 98209 69038 / +91 - 99875 90100

Ahmedabad : 38/2, Pancharatna Industrial Estate, B/h. Laxmi Narayan Petrol Pump, Sarkhej Bavla Rd. Changodar, Ahmedabad
- 382213, Gujarat | marketing@purencure.com | +91-99988 20566

Bhiwandi : B-11, Jai Shriram Complex, Near Monginis Cake Factory, Dapoda, Bhiwandi-421302, Maharashtra
nachiket@purencure.com | +91 - 98209 69038 / +91 - 99875 90100

Chennai : 140, New Colony, Koyambedu, Land mark : Behind St. Thomas College, Chennai – 600107, TAMIL NADU
musheer@purencure.com | +91 91766 94821 / +91 - 94447 86495

Delhi : Plot No. 209, Patpadganj Industrial Estate, Patpadganj, Nr. Anand Vihar Bus / Metro Station Delhi – 110092,
delhi@purencure.com | +91 98715 40780

Hyderabad : Plot B-3, IDA Uppal, Uppal, Hyderabad, Telengana - 500039 | hyderabad@purencure.com | +91 88974 86227

Odhao : 107, Neptune Industrial Park, Gate No - 4, Near Karnavati Estate, behind Royal Restaurant, S. P. Ring Road, Odhav -
Ahmedabad - 382415 | service@purencure.com | +91 99137 90229

Pune : 12, 'F' Wing, Steel India Compound, Mohan Nagar, Chinchwad, Pune – 411019, Maharashtra
sachin@purencure.com | +91 - 99875 90100 / +91 98209 69038

Kolkata : pradipta@purencure.com | +91 98300 25657

www.purencure.com



ASB

SUPER HIGH PRESSURE PUMP



www.purencure.com

CONTENTS

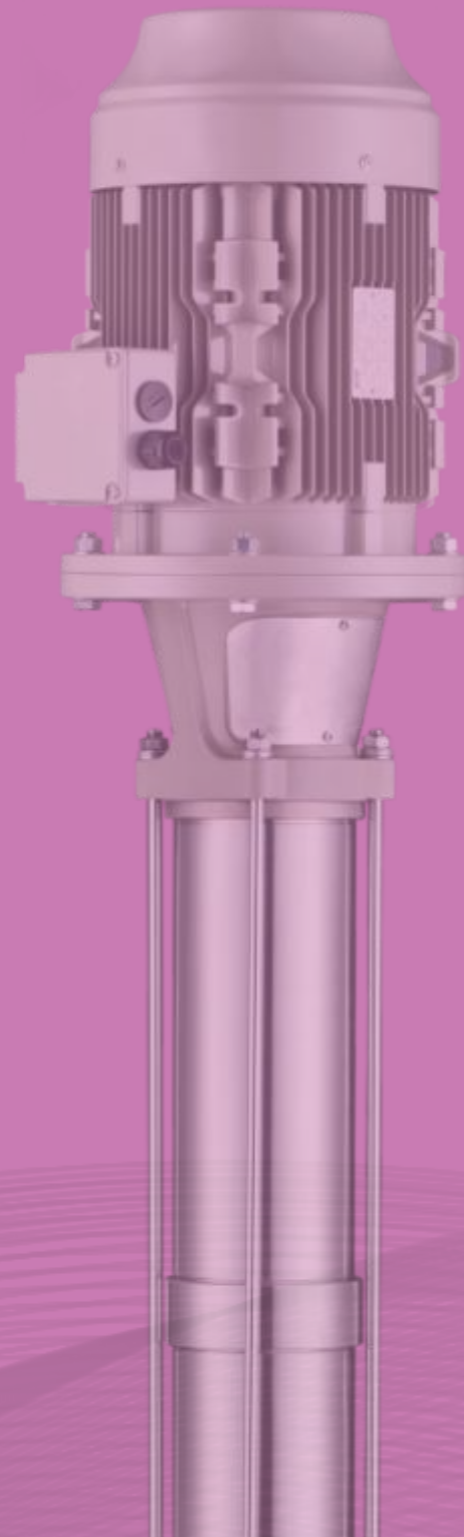

10	ASB 1	34	ASB 45
12	ASB 2	36	ASB 64
14	ASB 3	38	ASB 90
16	ASB 4	40	ASB 100
18	ASB 5	42	ASB 130
20	ASB 8	44	ASB 160
22	ASB 10	46	ASB 190
24	ASB 12	48	ASB 220
26	ASB 15	50	ASB 260
28	ASB 16	52	ASB 300
30	ASB 20	54	ASB 350
32	ASB 32	56	ASB 400
		58	ASB 450

Introduction

ASB are high-efficiency and energy-saving vertical multi-stage centrifugal pump. The centrifugal force generated by the impeller of the rotary pump drives the fluid to transfer. Its pump body and motor are composed of main shaft, impeller, diffuser, pump case and mechanical seal, and connected by coupling.

ASB series can be used as booster pump alone or as auxiliary booster equipment in the booster system of construction and industry. Its piping structure ensures that the pump is directly installed in the same horizontal piping system with the same diameter in and out.

This design makes the structure and piping of the pump more compact.

ASB series vertical multi-stage centrifugal pump can be installed vertically or horizontally on pipeline according to different installation space. In the case of horizontal installation, the pump needs to be added with fixed module to ensure the stability of the pump during operation.

Pipe connection

DIN flange, ANSI flange
Tri-Clamp

Pump material

Stainless steel(AISI304/1316)
Duplex stainless steel(2205)

Ambient temperature

If the ambient temperature exceeds the 40 °C or the pump is installed at an altitude exceeding 1000 m, the motor output power P2 will decrease. In such cases, it necessary to use a motor with a higher rated output.

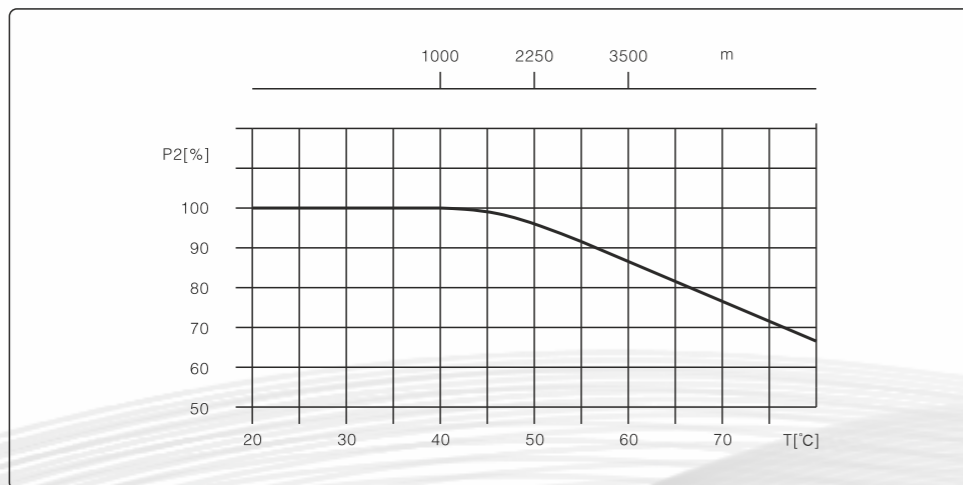

Motor

- Totally enclosed, fan-cooled, 2-pole standard motors
- Enclosure class: IP55
- Insulation class: F
- Voltage: 3x220-240/380-415V
1x220-240V
- Available with single-phase motors(0.37kW-2.2kW)

Liquid temperature °C

- Normal temperature pump: -15°C to +70°C
- Hot temperature pump: -15°C to +120°C

Performance curves

- The motors used for the measurements are based on 2900rpm or 2950 rpm
- Tolerances to ISO 9906
- Measurements have been made with airless water at a temperature of 20 °C
- The curves apply to the following kinematic viscosity: =1 mm²/s
- Select a best efficiency of the pump which is operating within the bold curve of the pump performance.

Pump operating conditions

- Pumping liquids which are thin, clean, non-flammable, non-combustible or non-explosive liquids, not containing solid particles or fibers.
- Maximum ambient temperature: +40 °C
- Maximum altitude above sea level: 1000 m

Pump performance range

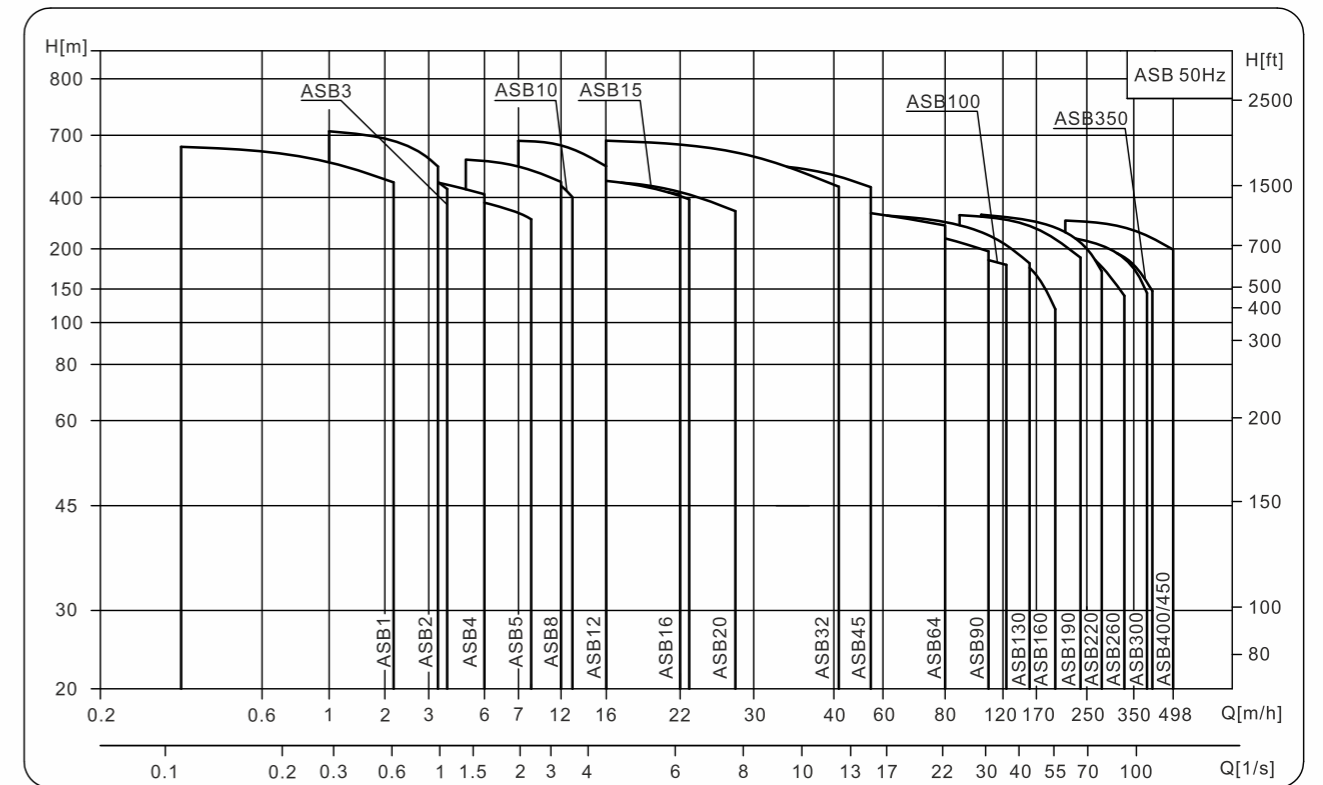

Minimum inlet pressure, NPSH

Cavitation may occur if the following conditions exist during the operation of the water pump:

- The water tank or pool is lower than the water pump inlet;
- High liquid temperature;
- Actual flow significantly greater than rated flow;
- Pressure in the pump lower than the vaporization pressure of the conveying liquid.

To avoid cavitation, make sure there is a minimum pressure on the inlet side of the pump. The maximum suction range H (m) can be calculated as follows:

$$H = P_b \cdot 10.2 - NPSH - H_f - H_v - H_s$$

P_b = Atmospheric pressure (atmospheric pressure can be set to 1bar), in closed system, P_b is system pressure

H_f = Net positive suction head (can be read from the maximum possible flow rate of the pump on the NPSH curve)

H_f = Pipeline loss at inlet

H_v = Vaporization pressure

H_s = Safety margin = Minimum 0.5m head

If the calculated value of H is positive, the pump can be operated at the maximum suction range H.

If the calculated H is negative, there must be a head with minimum inlet pressure H.

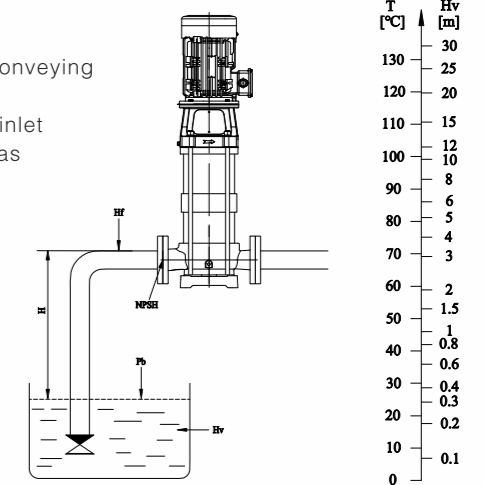

Make sure that the pump is not in a cavitation state

Model specification

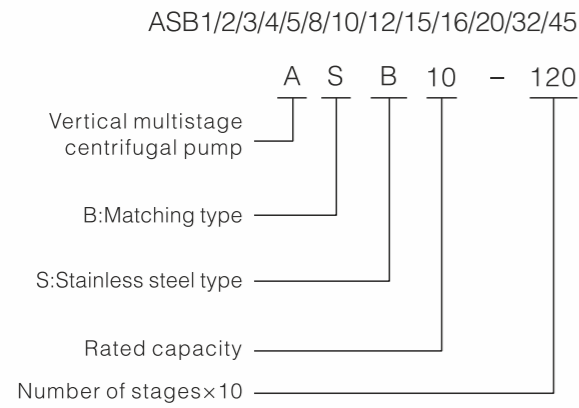

ASB64/90/100/130/160/190/230/260/300/350/400/450

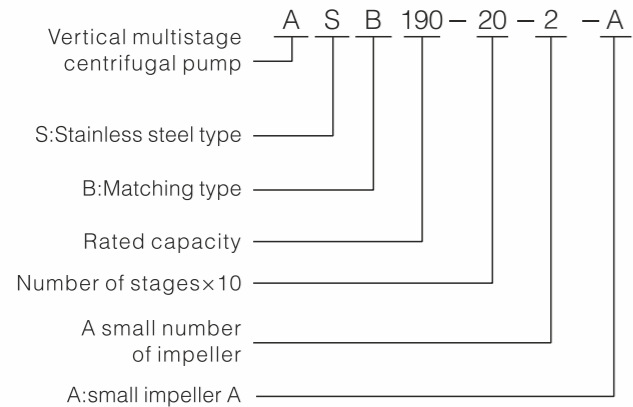

Applications

- Water supply
 - Water filter
 - Supercharging
 - Pressurization of hotels
 - Industrial pressurization
- Industrial boosting
 - Cleaning system
 - High pressure flushing system
 - Firefighting system
 - Car cleaning equipment
- Industrial liquid transport
 - Cooling air conditioning system
 - Boiler feed water
 - Condensing system and cooling tower
 - Machine tool cooling lubrication system
- Water treatment
 - Ultrafiltration system
 - Reverse osmosis system
 - Distillation system
 - Separator
 - Swimming pool
- Irrigation
 - Regional irrigation
 - Sprinkler irrigation
 - Drip irrigation
 - Greenhouse irrigation

Junction box position

In standard cases, the junction box is installed on the outlet side of the pump.

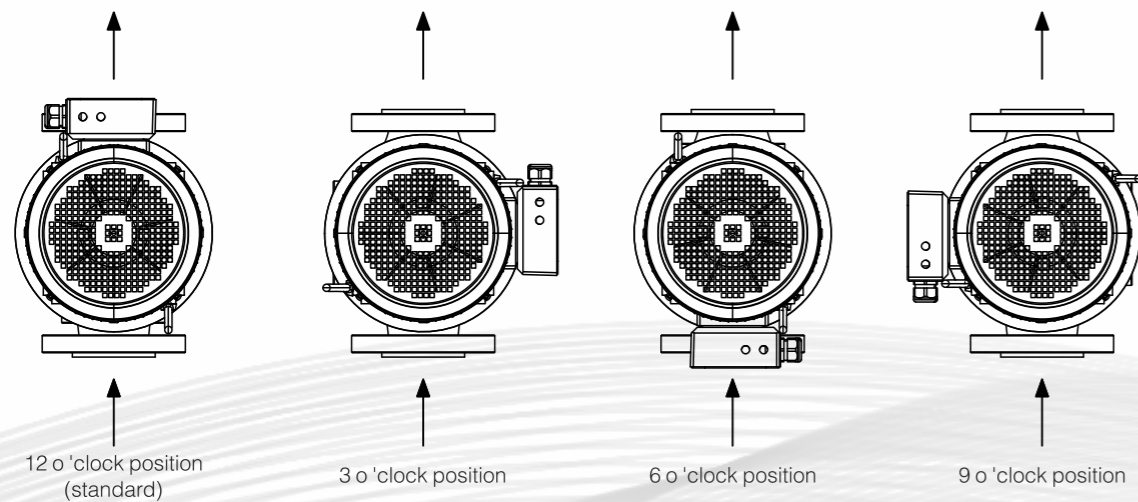

Product range introduction

Parameter	ASB1	ASB2	ASB3	ASB4	ASB5	ASB8	ASB10	ASB12	ASB15	ASB16	ASB20
Rated flow rate [m³/h]	1	2	3	4	5	8	10	12	15	16	20
Rated flow rate [l/s]	0.28	0.56	0.83	1.1	1.39	2.2	2.78	3.3	4.17	4.4	5.6
Flow rate [m³/h]	0.4~2.4	1~3.5	1.2~4	1.5~6	2.5~8.5	5~12	5~13	7~16	8~23	8~22	10~28
Flow rate [l/s]	0.11~0.66	0.28~0.97	0.33~1.1	0.42~1.63	0.69~2.36	1.39~3.3	1.39~3.61	1.9~4.4	2.22~6.39	2.2~6.1	2.8~7.8
Maximum pressure [bar]	64	73	59	55	41	59	57	70	49	50	50
Power [kW]	4~5.5	5.5~9.2	5.5~9.2	9.2~15	9.2~11	15~30	15~30	22~45	30~37	30~37	30~45
Temperature range [°C]	-15~+120										
Highest efficiency [%]	48	52	57	57	66	62	68	63	68	66	68
ASB Pipe connection											
DIN flange	DN25	DN25	DN25	DN32	DN32	DN40	DN40	DN50	DN50	DN50	DN50
Clamp connection	DN32	DN32	DN32	DN32	DN32	DN50	DN50	DN50	DN50	DN50	DN50

Parameter	ASB32	ASB45	ASB64	ASB90	ASB100	ASB130	ASB160	ASB190	ASB220	ASB260	ASB300	ASB350	ASB400	ASB450
Rated flow rate [m³/h]	32	45	64	90	100	130	160	190	220	260	300	350	400	450
Rated flow rate [l/s]	8.9	12.5	17.8	25	27.78	36.11	44.44	52.78	61.11	72.22	83.4	97.3	111.2	125.1
Flow rate [m³/h]	16~42	25~55	30~80	50~110	50~125	60~160	80~200	90~240	105~282	125~330	160~400	180~420	216~498	216~498
Flow rate [l/s]	4.4~11	6.9~15.3	8~22	14~30	14~34.7	16.7~44.4	22.2~55.6	25~66.7	29.2~78.3	34.7~91.7	44.5~111.2	50~116.8	60~138.4	60~138.4
Maximum pressure [bar]	70	58	37	34	37	33	27	34	34	27	28	24	34	34
Power [kW]	55~90	75~90	55~90	55~90	55~90	11~110	11~110	18.5~200	22~200	30~200	30~220	37~220	75~355	75~355
Temperature range [°C]	-15~+120													
Highest efficiency [%]	75	77	78	79	81	82	82	82	83	84	83	85	86	86
Pipe connection														
DIN flange	DN65	DN80	DN100	DN100	DN100	DN150	DN150	DN200	DN200	DN200	DN250	DN250	DN250	DN250

Structure ASB1,2,3,4,5

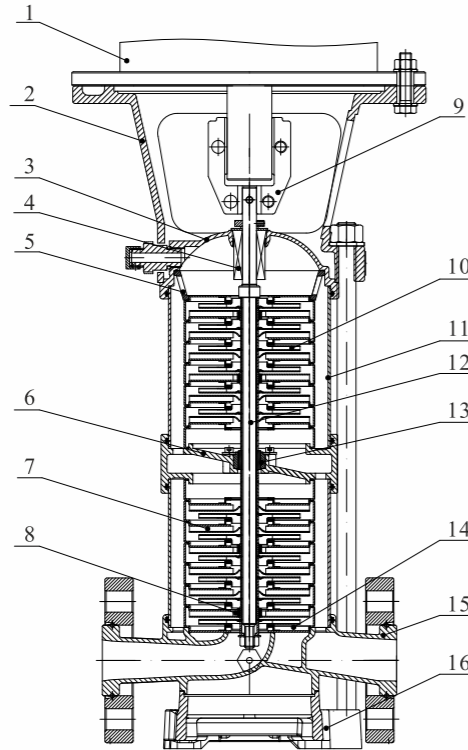

Materials ASB1,2,3,4,5

No.	Spare parts	Materials	GB	EN/DIN	AISI/ASTW
1	Motor	/	/	/	/
2	Bracket	Ductile cast iron	GB1348-QT550-7	EN 1563 EN-GJS-500-7	ASTM A56 65-45-12
3	Seal base	Stainless steel	GB/T20878-06Cr19Ni10	EN 10088-1.4301	AISI304
4	Mechanical seal	/	/	/	/
5	Water inlet positioner	Stainless steel	GB/T20878-06Cr19Ni10	EN 10088-1.4301	AISI304
6	Supporting the diversion layer	Stainless steel	GB/T20878-06Cr19Ni10	EN 10088-1.4301	AISI304
7	Diffuser	Stainless steel	GB/T20878-06Cr19Ni10	EN 10088-1.4301	AISI304
8	Support diffuser	Stainless steel	GB/T20878-06Cr19Ni10	EN 10088-1.4301	AISI304
9	Coupling	Ductile cast iron	GB 1348-QT500-7	EN 1563 EN-GJS-500-7	ASTM A56 65-45-12
10	Impeller	Stainless steel	GB/T20878-06Cr19Ni10	/	AISI304
11	Cylinder	Stainless steel	GB/T20878-06Cr19Ni10	EN 10088-1.4301	AISI304
12	Shaft	Stainless steel	GB/T20878-06Cr19Ni10	EN 10088-1.4301	AISI304
13	Bearing	WC	/	/	/
14	Inducer	Stainless steel	GB/T20878-06Cr19Ni10	EN 10088-1.4301	AISI304
15	Intel&outlet chamber	Stainless steel	GB/T20878-06Cr19Ni10	EN 10088-1.4301	AISI304
16	Base	Ductile cast iron	GB 1348-QT500-7	EN 1563 EN-GJS-500-7	ASTM A56 65-45-12

Structure ASB8,10,12,15,16,20

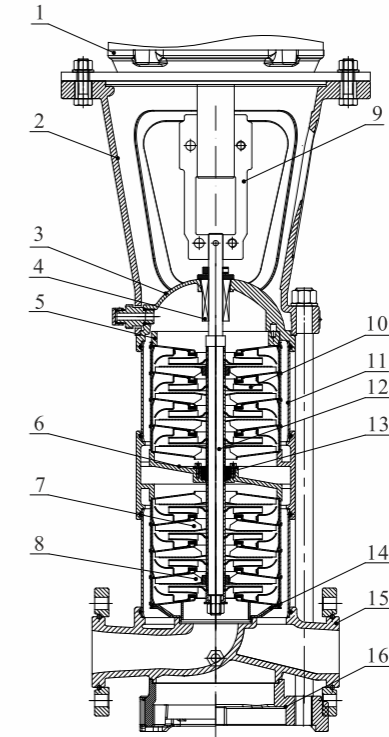

Materials ASB8,10,12,15,16,20

No.	Spare parts	Materials	GB	EN/DIN	AISI/ASTW
1	Motor	/	/	/	/
2	Bracket	Ductile cast iron	GB1348-QT550-7	EN 1563 EN-GJS-500-7	ASTM A56 65-45-12
3	Seal base	Stainless steel	GB/T20878-06Cr19Ni10	EN 10088-1.4301	AISI304
4	Mechanical seal	/	/	/	/
5	Water inlet positioner	Stainless steel	GB/T20878-06Cr19Ni10	EN 10088-1.4301	AISI304
6	Supporting the diversion layer	Stainless steel	GB/T20878-06Cr19Ni10	EN 10088-1.4301	AISI304
7	Diffuser	Stainless steel	GB/T20878-06Cr19Ni10	EN 10088-1.4301	AISI304
8	Support diffuser	Stainless steel	GB/T20878-06Cr19Ni10	EN 10088-1.4301	AISI304
9	Coupling	Ductile cast iron	GB 1348-QT500-7	EN 1563 EN-GJS-500-7	ASTM A56 65-45-12
10	Impeller	Stainless steel	GB/T20878-06Cr19Ni10	/	AISI304
11	Cylinder	Stainless steel	GB/T20878-06Cr19Ni10	EN 10088-1.4301	AISI304
12	Shaft	Stainless steel	GB/T20878-06Cr19Ni10	EN 10088-1.4301	AISI304
13	Bearing	WC	/	/	/
14	Inducer	Stainless steel	GB/T20878-06Cr19Ni10	EN 10088-1.4301	AISI304
15	Intel&outlet chamber	Stainless steel	GB/T20878-06Cr19Ni10	EN 10088-1.4301	AISI304
16	Base	Ductile cast iron	GB 1348-QT500-7	EN 1563 EN-GJS-500-7	ASTM A56 65-45-12

Structure ASB32,45,64,90

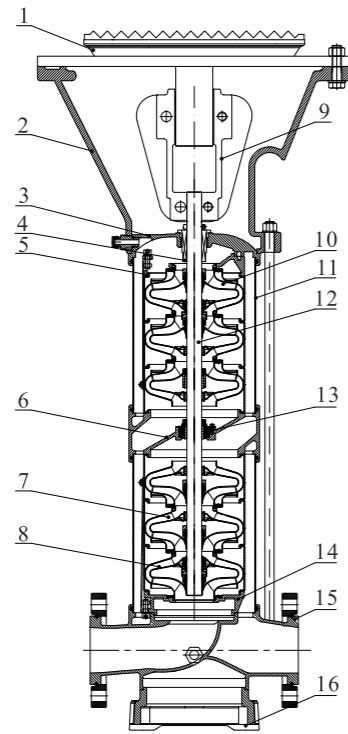

Materials ASB32,45,64,90

No.	Spare parts	Materials	GB	EN/DIN	AISI/ASTW
1	Motor	/	/	/	/
2	Bracket	Ductile cast iron	GB1348-QT550-7	EN 1563 EN-GJS-500-7	ASTM A56 65-45-12
3	Seal base	Stainless steel	GB/T20878-06Cr19Ni10	EN 10088-1.4301	AISI304
4	Mechanical seal	/	/	/	/
5	Water inlet positioner	Stainless steel	GB/T20878-06Cr19Ni10	EN 10088-1.4301	AISI304
6	Supporting the diversion layer	Stainless steel	GB/T20878-06Cr19Ni10	EN 10088-1.4301	AISI304
7	Diffuser	Stainless steel	GB/T20878-06Cr19Ni10	EN 10088-1.4301	AISI304
8	Support diffuser	Stainless steel	GB/T20878-06Cr19Ni10	EN 10088-1.4301	AISI304
9	Coupling	Ductile cast iron	GB 1348-QT500-7	EN 1563 EN-GJS-500-7	ASTM A56 65-45-12
10	Impeller	Stainless steel	GB/T20878-06Cr19Ni10	/	AISI304
11	Cylinder	Stainless steel	GB/T20878-06Cr19Ni10	EN 10088-1.4301	AISI304
12	Shaft	Stainless steel	GB/T20878-06Cr19Ni10	EN 10088-1.4301	AISI304
13	Bearing	WC	/	/	/
14	Inducer	Stainless steel	GB/T20878-06Cr19Ni10	EN 10088-1.4301	AISI304
15	Intel&outlet chamber	Stainless steel	GB/T20878-06Cr19Ni10	EN 10088-1.4301	AISI304
16	Base	Ductile cast iron	GB 1348-QT500-7	EN 1563 EN-GJS-500-7	ASTM A56 65-45-12

Structure ASB100,130,160,190,220,260,300,350,400,450

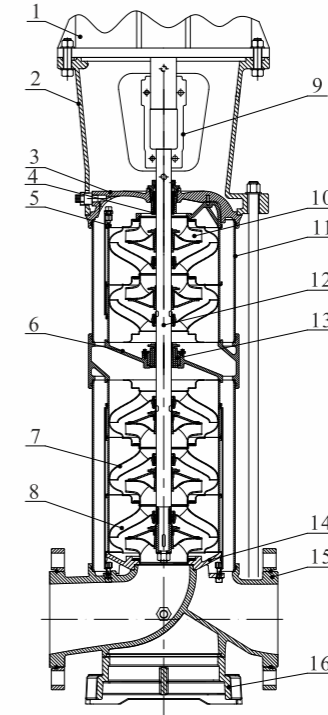

Materials ASB100,130,160,190,220,260,300,350,400,450

No.	Spare parts	Materials	GB	EN/DIN	AISI/ASTW
1	Motor	/	/	/	/
2	Bracket	Ductile cast iron	GB1348-QT550-7	EN 1563 EN-GJS-500-7	ASTM A56 65-45-12
3	Seal base	Stainless steel	GB/T20878-06Cr19Ni10	EN 10088-1.4301	AISI304
4	Mechanical seal	/	/	/	/
5	Water inlet positioner	Stainless steel	GB/T20878-06Cr19Ni10	EN 10088-1.4301	AISI304
6	Supporting the diversion layer	Stainless steel	GB/T20878-06Cr19Ni10	EN 10088-1.4301	AISI304
7	Diffuser	Stainless steel	GB/T20878-06Cr19Ni10	EN 10088-1.4301	AISI304
8	Support diffuser	Stainless steel	GB/T20878-06Cr19Ni10	EN 10088-1.4301	AISI304
9	Coupling	Ductile cast iron	GB 1348-QT500-7	EN 1563 EN-GJS-500-7	ASTM A56 65-45-12
10	Impeller	Stainless steel	GB/T20878-06Cr19Ni10	/	AISI304
11	Cylinder	Stainless steel	GB/T20878-06Cr19Ni10	EN 10088-1.4301	AISI304
12	Shaft	Stainless steel	GB/T20878-06Cr19Ni10	EN 10088-1.4301	AISI304
13	Bearing	WC	/	/	/
14	Inducer	Stainless steel	GB/T20878-06Cr19Ni10	EN 10088-1.4301	AISI304
15	Intel&outlet chamber	Stainless steel	GB/T20878-06Cr19Ni10	EN 10088-1.4301	AISI304
16	Base	Ductile cast iron	GB 1348-QT500-7	EN 1563 EN-GJS-500-7	ASTM A56 65-45-12

Installation dimensions and weight

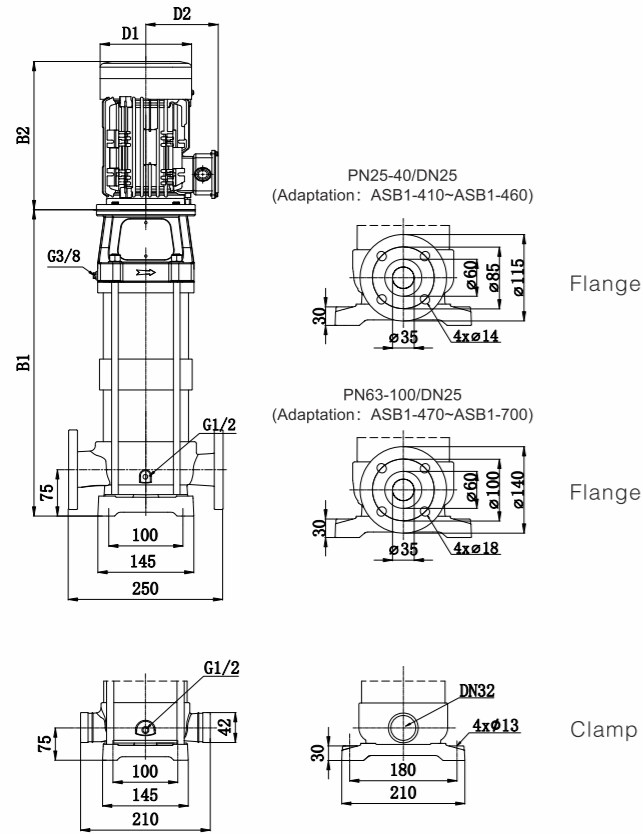

Model	Dimension(mm)					Weight (kg)
	B1	B2	B1+B2	D1	D2	
ASB1-410	1075	354	1429	220	172	83
ASB1-420	1093	354	1447	220	172	84
ASB1-430	1111	354	1465	220	172	84
ASB1-440	1129	354	1483	220	172	85
ASB1-450	1147	354	1501	220	172	86
ASB1-460	1165	354	1519	220	172	87
ASB1-470	1183	354	1537	220	172	87
ASB1-480	1201	354	1555	220	172	88
ASB1-490	1219	354	1573	220	172	89
ASB1-500	1237	354	1591	220	172	90
ASB1-510	1255	354	1609	220	172	90
ASB1-520	1273	354	1627	220	172	91
ASB1-530	1291	354	1645	220	172	92
ASB1-540	1309	354	1663	220	172	93
ASB1-550	1347	414	1761	259	192	107
ASB1-560	1365	414	1779	259	192	108
ASB1-570	1383	414	1797	259	192	109
ASB1-580	1401	414	1815	259	192	110
ASB1-590	1419	414	1833	259	192	110
ASB1-600	1437	414	1851	259	192	111
ASB1-610	1455	414	1869	259	192	112
ASB1-620	1473	414	1887	259	192	113
ASB1-630	1491	414	1905	259	192	113
ASB1-640	1509	414	1923	259	192	114
ASB1-650	1527	414	1941	259	192	115
ASB1-660	1545	414	1959	259	192	116
ASB1-670	1563	414	1977	259	192	117
ASB1-680	1581	414	1995	259	192	117
ASB1-690	1599	414	2013	259	192	118
ASB1-700	1617	414	2031	259	192	119

Performance data

Model	Power(kW)	Q (m³/h)	H (m)											
			0.4	0.6	0.8	1.0	1.2	1.4	1.6	1.8	2.0	2.2	2.4	
ASB1-410	4.0		361	356	350	344	335	326	317	306	293	281	267	
ASB1-420	4.0		370	365	359	352	344	334	325	313	301	288	274	
ASB1-430	4.0		379	374	367	361	352	343	333	321	308	295	280	
ASB1-440	4.0		388	383	376	370	361	351	341	329	316	302	287	
ASB1-450	4.0		397	392	385	378	369	359	349	337	323	310	294	
ASB1-460	4.0		406	401	394	387	378	367	357	344	330	317	301	
ASB1-470	4.0		415	409	402	395	386	375	365	352	338	324	307	
ASB1-480	4.0		424	418	411	404	394	384	373	360	345	331	314	
ASB1-490	4.0		433	427	420	413	403	392	381	367	353	338	321	
ASB1-500	4.0		443	436	429	421	411	400	389	375	360	345	328	
ASB1-510	4.0		452	445	438	430	420	408	397	383	367	352	334	
ASB1-520	4.0		461	454	446	439	428	416	405	390	375	359	341	
ASB1-530	4.0		470	463	455	447	437	425	413	398	382	366	348	
ASB1-540	4.0		479	472	464	456	445	433	421	406	390	373	355	
ASB1-550	5.5		488	481	473	464	453	441	429	414	397	381	361	
ASB1-560	5.5		497	490	481	473	462	449	437	421	404	388	368	
ASB1-570	5.5		506	499	490	482	470	457	445	429	412	395	375	
ASB1-580	5.5		515	508	499	490	479	466	453	437	419	402	382	
ASB1-590	5.5		524	517	508	499	487	474	461	444	427	409	388	
ASB1-600	5.5		533	526	517	508	496	482	469	452	434	416	395	
ASB1-610	5.5		542	534	525	516	504	490	476	460	441	423	402	
ASB1-620	5.5		551	543	534	525	512	498	484	467	449	430	409	
ASB1-630	5.5		560	552	543	533	521	507	492	475	456	437	415	
ASB1-640	5.5		569	561	552	542	529	515	500	483	464	444	422	
ASB1-650	5.5		578	570	560	551	538	523	508	491	471	452	429	
ASB1-660	5.5		587	579	569	559	546	531	516	498	478	459	436	
ASB1-670	5.5		596	588	578	568	554	539	524	506	486	466	442	
ASB1-680	5.5		605	597	587	577	563	548	532	514	493	473	449	
ASB1-690	5.5		614	606	595	585	571	556	540	521	501	480	456	
ASB1-700	5.5		624	615	604	594	580	564	548	529	508	487	463	

Performance curve

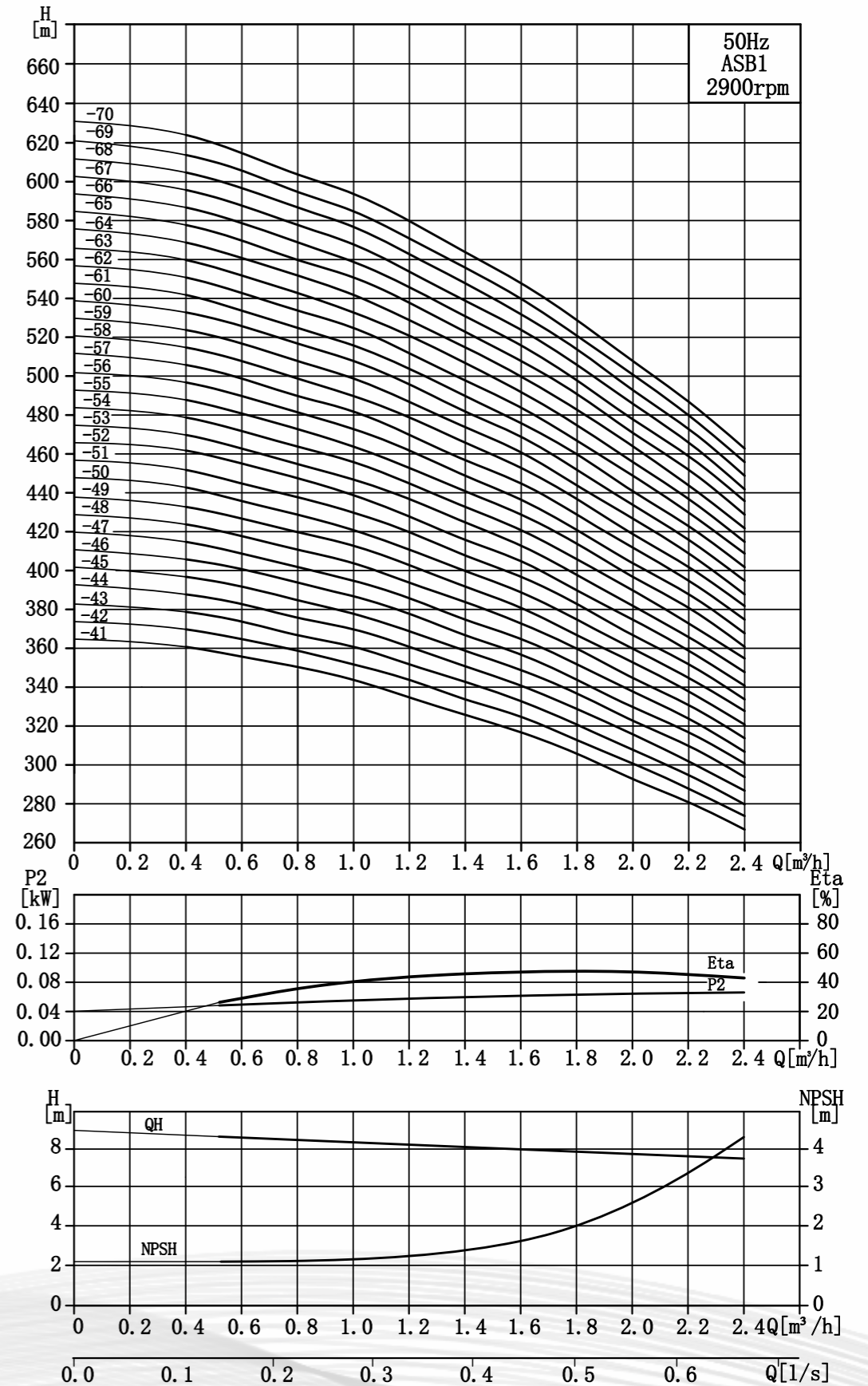

Installation dimensions and weight

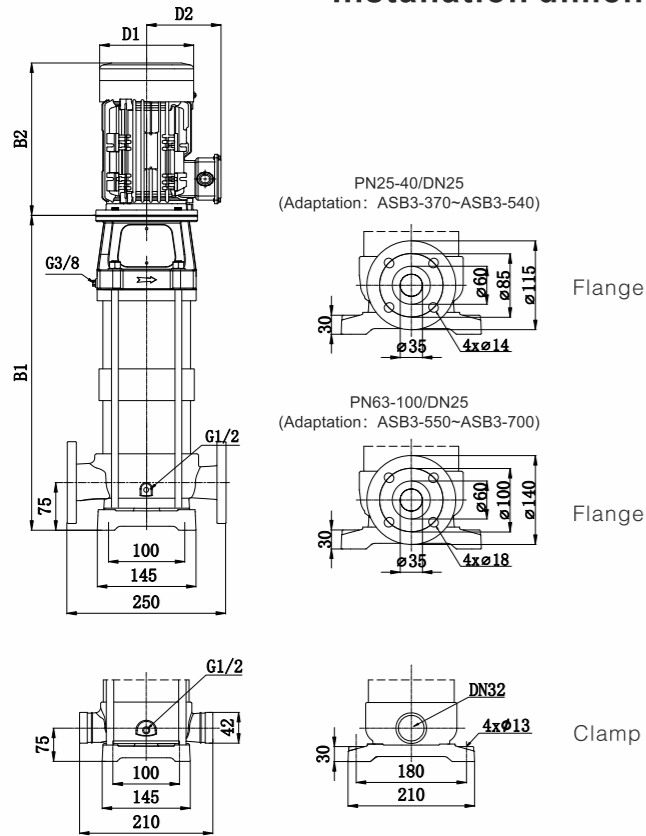

Model	Dimension(mm)					Weight (kg)
	B1	B2	B1+B2	D1	D2	
ASB3-370	1013	414	1427	259	192	97
ASB3-380	1031	414	1445	259	192	98
ASB3-390	1049	414	1463	259	192	99
ASB3-400	1067	414	1481	259	192	99
ASB3-410	1085	414	1499	259	192	100
ASB3-420	1103	414	1517	259	192	101
ASB3-430	1121	414	1535	259	192	102
ASB3-440	1139	414	1553	259	192	103
ASB3-450	1157	414	1571	259	192	110
ASB3-460	1175	414	1589	259	192	111
ASB3-470	1193	414	1607	259	192	111
ASB3-480	1211	414	1625	259	192	112
ASB3-490	1229	414	1643	259	192	113
ASB3-500	1247	414	1661	259	192	114
ASB3-510	1265	414	1679	259	192	115
ASB3-520	1283	414	1697	259	192	116
ASB3-530	1301	414	1715	259	192	116
ASB3-540	1319	414	1733	259	192	117
ASB3-550	1337	414	1751	259	192	118
ASB3-560	1355	414	1769	259	192	119
ASB3-570	1373	414	1787	259	192	120
ASB3-580	1391	414	1805	259	192	121
ASB3-590	1409	414	1823	259	192	122
ASB3-600	1427	414	1841	259	192	122
ASB3-610	1466	414	1880	259	192	123
ASB3-620	1484	414	1898	259	192	124
ASB3-630	1502	414	1916	259	192	125
ASB3-640	1520	414	1934	259	192	126
ASB3-650	1538	414	1952	259	192	127
ASB3-660	1556	414	1970	259	192	128
ASB3-670	1574	414	1988	259	192	128
ASB3-680	1592	414	2006	259	192	129
ASB3-690	1610	414	2024	259	192	130
ASB3-700	1628	414	2042	259	192	131

Performance data

Model	Power(kW)	Q (m³/h)	H (m)										
			1.2	1.6	2.0	2.4	2.8	3.0	3.2	3.6	4.0		
ASB3-370	5.5		296	292	286	279	270	264	2257	241	223		
ASB3-380	5.5		304	300	294	287	278	271	264	248	229		
ASB3-390	5.5		313	308	302	295	285	279	271	255	236		
ASB3-400	5.5		321	316	310	302	293	286	279	261	242		
ASB3-410	5.5		329	325	318	310	300	294	286	268	248		
ASB3-420	5.5		337	333	326	318	308	301	293	275	254		
ASB3-430	5.5		346	341	334	326	315	308	300	282	261		
ASB3-440	5.5		354	349	342	334	323	316	308	288	267		
ASB3-450	7.5		362	357	350	341	331	323	315	295	273		
ASB3-460	7.5		370	365	358	349	338	331	322	302	280		
ASB3-470	7.5		379	374	366	357	346	338	329	309	286		
ASB3-480	7.5		387	382	374	365	353	345	336	316	292		
ASB3-490	7.5		395	390	382	373	361	353	344	322	299		
ASB3-500	7.5		404	398	390	381	368	360	351	329	305		
ASB3-510	7.5		412	406	398	388	376	368	358	336	311		
ASB3-520	7.5		420	414	406	396	384	375	365	343	317		
ASB3-530	7.5		428	423	414	404	391	382	372	350	324		
ASB3-540	7.5		437	431	422	412	399	390	380	356	330		
ASB3-550	7.5		445	439	430	420	406	397	387	363	336		
ASB3-560	7.5		453	447	438	427	414	405	394	370	343		
ASB3-570	7.5		461	455	446	435	421	412	401	377	349		
ASB3-580	7.5		470	463	454	443	429	420	409	383	355		
ASB3-590	7.5		478	472	462	451	436	427	416	390	362		
ASB3-600	7.5		486	480	470	459	444	434	423	397	368		
ASB3-610	9.2		494	488	478	466	452	442	430	404	374		
ASB3-620	9.2		503	496	486	474	459	449	437	411	380		
ASB3-630	9.2		511	504	494	482	467	457	445	417	387		
ASB3-640	9.2		519	512	502	490	474	464	452	424	393		
ASB3-650	9.2		528	521	510	498	482	471	459	431	399		
ASB3-660	9.2		536	529	518	506	489	479	466	438	406		
ASB3-670	9.2		544	537	526	513	497	486	473	445	412		
ASB3-680	9.2		552	545	534	521	505	494	481	451	418		
ASB3-690	9.2		561	553	542	529	512	501	488	458	425		
ASB3-700	9.2		569	561	550	537	520	508	495	465	431		

Performance curve

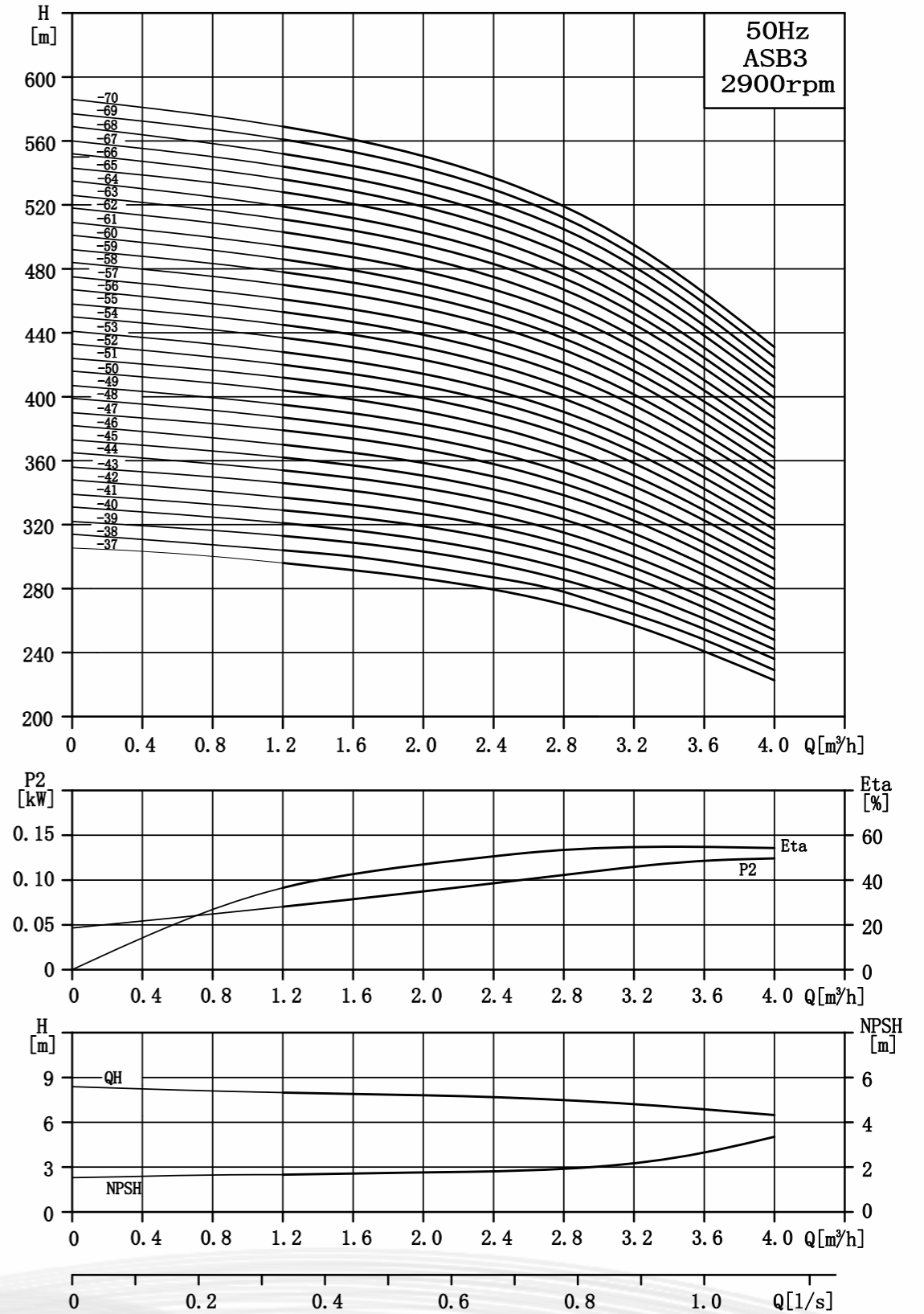

Installation dimensions and weight

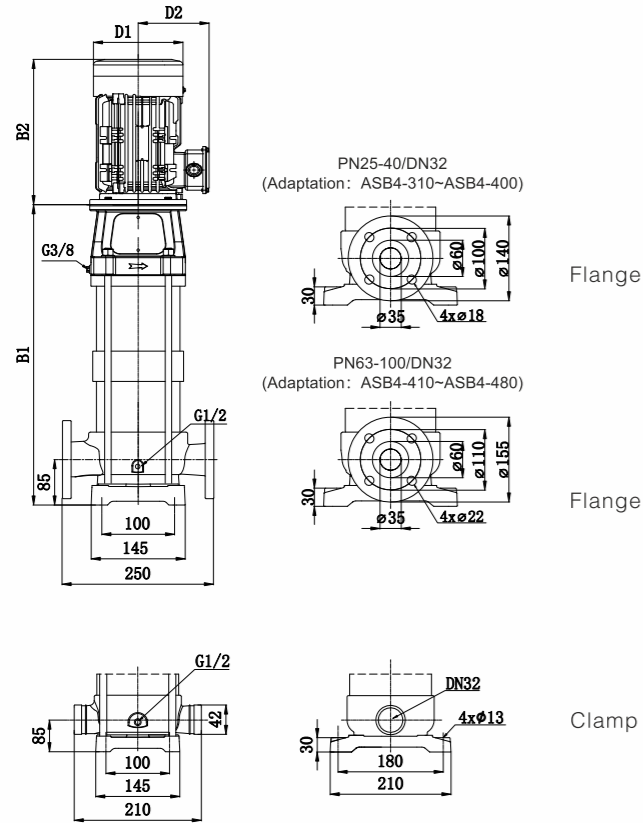

Model	Dimension(mm)					Weight (kg)
	B1	B2	B1+B2	D1	D2	
ASB4-310	1233	414	1647	259	192	102
ASB4-320	1260	414	1674	259	192	103
ASB4-330	1287	414	1701	259	192	104
ASB4-340	1314	414	1728	259	192	105
ASB4-350	1341	414	1755	259	192	106
ASB4-360	1368	414	1782	259	192	107
ASB4-370	1425	523	1948	311	235	171
ASB4-380	1452	523	1975	311	235	171
ASB4-390	1479	523	2002	311	235	172
ASB4-400	1506	523	2029	311	235	173
ASB4-410	1533	523	2056	311	235	174
ASB4-420	1560	523	2083	311	235	175
ASB4-430	1587	523	2110	311	235	176
ASB4-440	1614	523	2137	311	235	177
ASB4-450	1641	523	2164	311	235	178
ASB4-460	1668	523	2191	311	235	179
ASB4-470	1695	523	2218	311	235	187
ASB4-480	1722	523	2245	311	235	188

Performance data

Model	Power(kW)	Q (m³/h)	H (m)					
			1.5	2.0	3.0	4.0	5.0	6.0
ASB4-310	7.5		336	331	319	305	286	264
ASB4-320	9.2		347	342	330	315	296	272
ASB4-330	9.2		358	353	340	325	305	281
ASB4-340	9.2		369	363	351	335	315	290
ASB4-350	9.2		380	374	361	345	324	298
ASB4-360	9.2		391	385	372	355	333	307
ASB4-370	11		402	396	382	365	343	316
ASB4-380	11		413	407	393	375	352	324
ASB4-390	11		424	418	403	385	362	333
ASB4-400	11		435	428	414	395	371	342
ASB4-410	11		446	439	424	405	380	350
ASB4-420	11		457	450	435	415	390	359
ASB4-430	11		468	461	445	425	399	368
ASB4-440	11		479	472	456	435	409	376
ASB4-450	11		490	483	466	445	418	385
ASB4-460	11		501	493	476	455	427	394
ASB4-470	15		512	504	487	465	437	402
ASB4-480	15		523	515	497	475	446	411

Performance curve

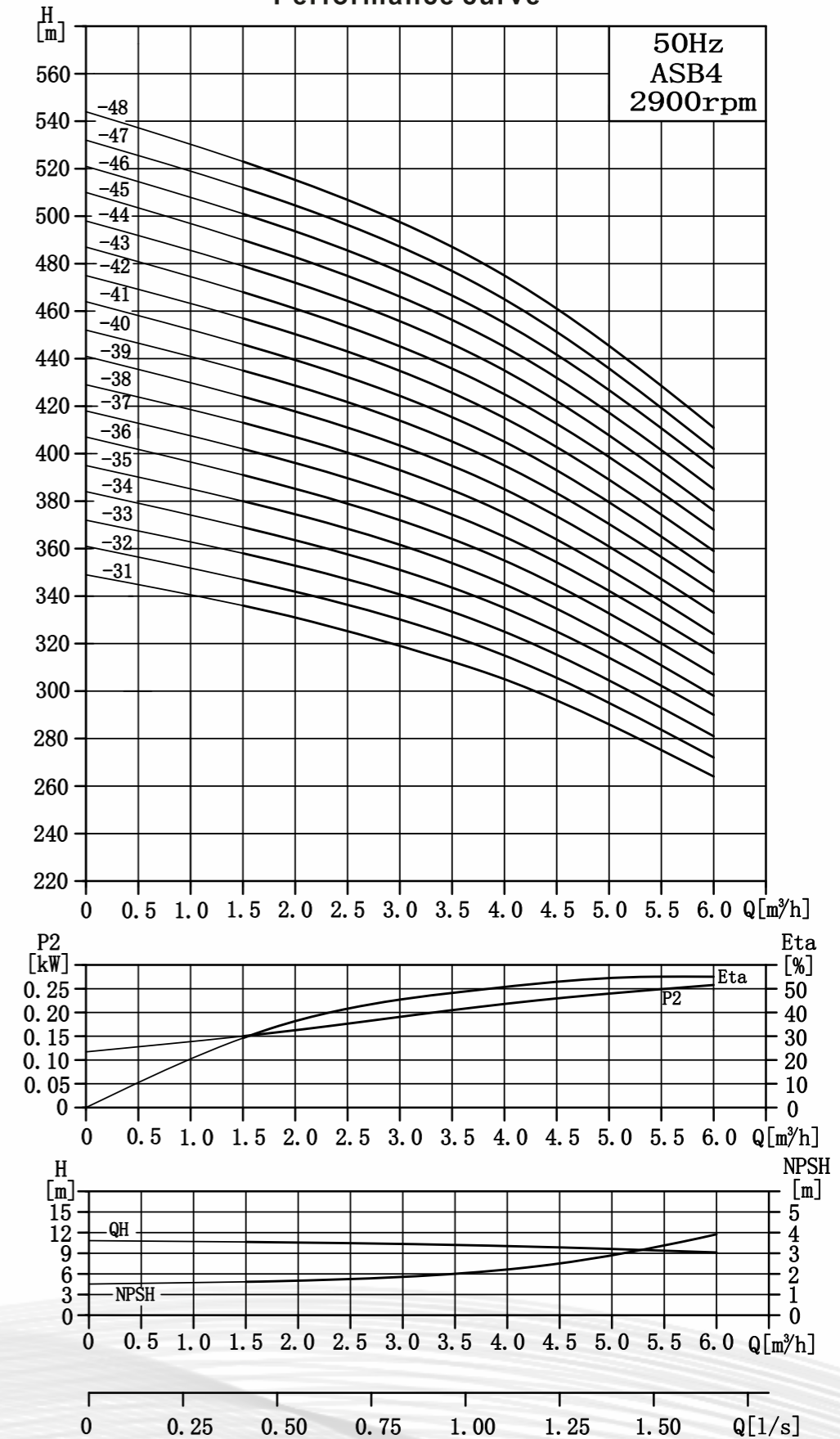

Installation dimensions and weight

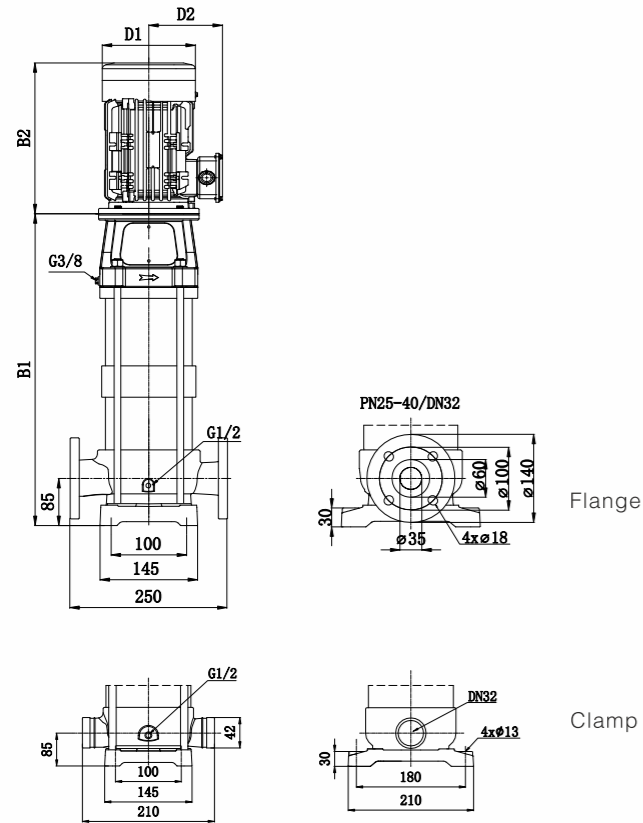

Model	Dimension(mm)					Weight (kg)
	B1	B2	B1+B2	D1	D2	
ASB5-390	1449	414	1863	259	192	113
ASB5-400	1476	414	1890	259	192	114
ASB5-410	1503	414	1917	259	192	115
ASB5-420	1530	414	1944	259	192	116
ASB5-430	1557	414	1971	259	192	117
ASB5-440	1584	414	1998	259	192	118
ASB5-450	1611	414	2025	259	192	119
ASB5-460	1638	414	2052	259	192	120
ASB5-470	1695	523	2218	311	235	184
ASB5-480	1722	523	2245	311	235	185

Performance data

Model	Power(kW)	Q (m³/h)	H (m)							
			2.5	4.0	5.0	6.0	7.0	8.5		
ASB5-390	9.2	H (m)	317	310	302	291	276	246		
ASB5-400	9.2		326	318	310	299	284	253		
ASB5-410	9.2		334	327	318	306	291	259		
ASB5-420	9.2		343	335	326	314	298	266		
ASB5-430	9.2		351	343	334	322	306	272		
ASB5-440	9.2		359	351	342	329	313	279		
ASB5-450	9.2		368	359	350	337	320	286		
ASB5-460	9.2		376	368	358	345	328	292		
ASB5-470	11		385	376	366	353	335	299		
ASB5-480	11		393	384	374	360	342	305		

Performance curve

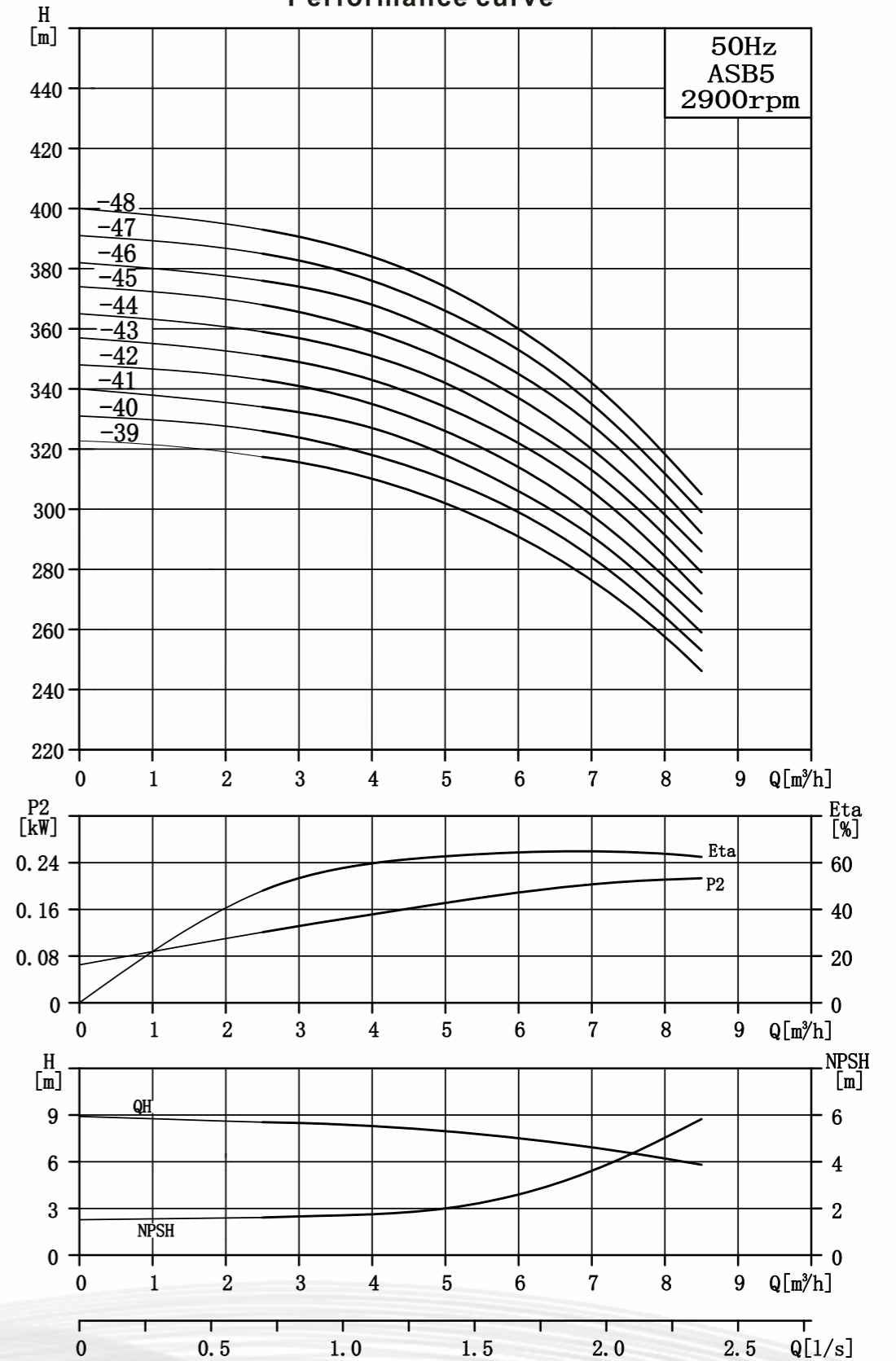

Installation dimensions and weight

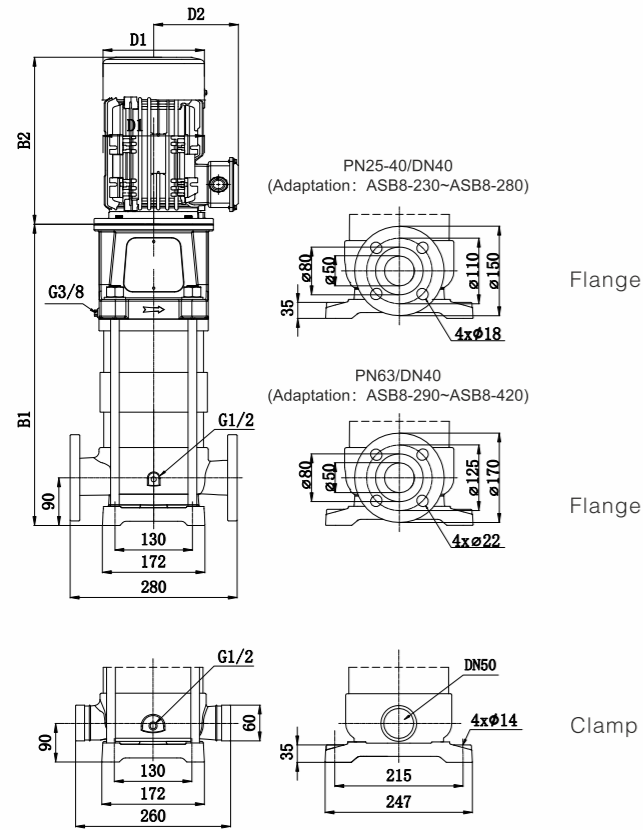

Model	Dimension(mm)					Weight (kg)
	B1	B2	B1+B2	D1	D2	
ASB8-230	1187	523	1710	311	235	181
ASB8-240	1217	523	1740	311	235	182
ASB8-250	1247	523	1770	311	235	184
ASB8-260	1277	523	1800	311	235	185
ASB8-270	1307	523	1830	311	235	187
ASB8-280	1337	578	1915	311	235	211
ASB8-290	1367	578	1945	311	235	212
ASB8-300	1397	578	1975	311	235	214
ASB8-310	1427	578	2005	311	235	215
ASB8-320	1457	578	2035	311	235	217
ASB8-330	1487	578	2065	311	235	251
ASB8-340	1517	578	2095	311	235	252
ASB8-350	1547	578	2125	311	235	254
ASB8-360	1577	578	2155	311	235	255
ASB8-370	1607	578	2185	311	235	257
ASB8-380	1662	666	2328	397	305	327
ASB8-390	1692	666	2358	397	305	328
ASB8-400	1722	666	2388	397	305	330
ASB8-410	1752	666	2418	397	305	331
ASB8-420	1782	666	2448	397	305	333

Performance data

Model	Power(kW)	Q (m³/h)	H (m)																	
			5.0	6.0	7.0	8.0	9.0	10.0	11.0	12.0										
ASB8-230	15		329	325	318	310	301	291	281	270										
ASB8-240	15		343	338	332	323	314	304	293	281										
ASB8-250	15		357	352	345	336	327	316	305	293										
ASB8-260	15		371	366	358	349	339	328	316	304										
ASB8-270	15		385	379	372	362	352	340	328	315										
ASB8-280	18.5		399	393	385	375	364	352	340	327										
ASB8-290	18.5		413	407	399	388	377	365	352	338										
ASB8-300	18.5		426	420	412	402	390	377	363	349										
ASB8-310	18.5		440	434	425	415	402	389	375	361										
ASB8-320	18.5		454	448	439	428	415	401	387	372										
ASB8-330	22		468	461	452	441	428	414	399	383										
ASB8-340	22		482	475	466	454	440	426	411	395										
ASB8-350	22		496	489	479	467	453	438	422	406										
ASB8-360	22		510	502	492	480	466	450	434	417										
ASB8-370	22		524	516	506	493	478	463	446	428										
ASB8-380	30		537	530	519	506	491	475	458	440										
ASB8-390	30		551	544	533	519	504	487	469	451										
ASB8-400	30		565	557	546	532	516	499	481	462										
ASB8-410	30		579	571	559	545	529	511	493	474										
ASB8-420	30		593	585	573	558	542	524	505	485										

Performance curve

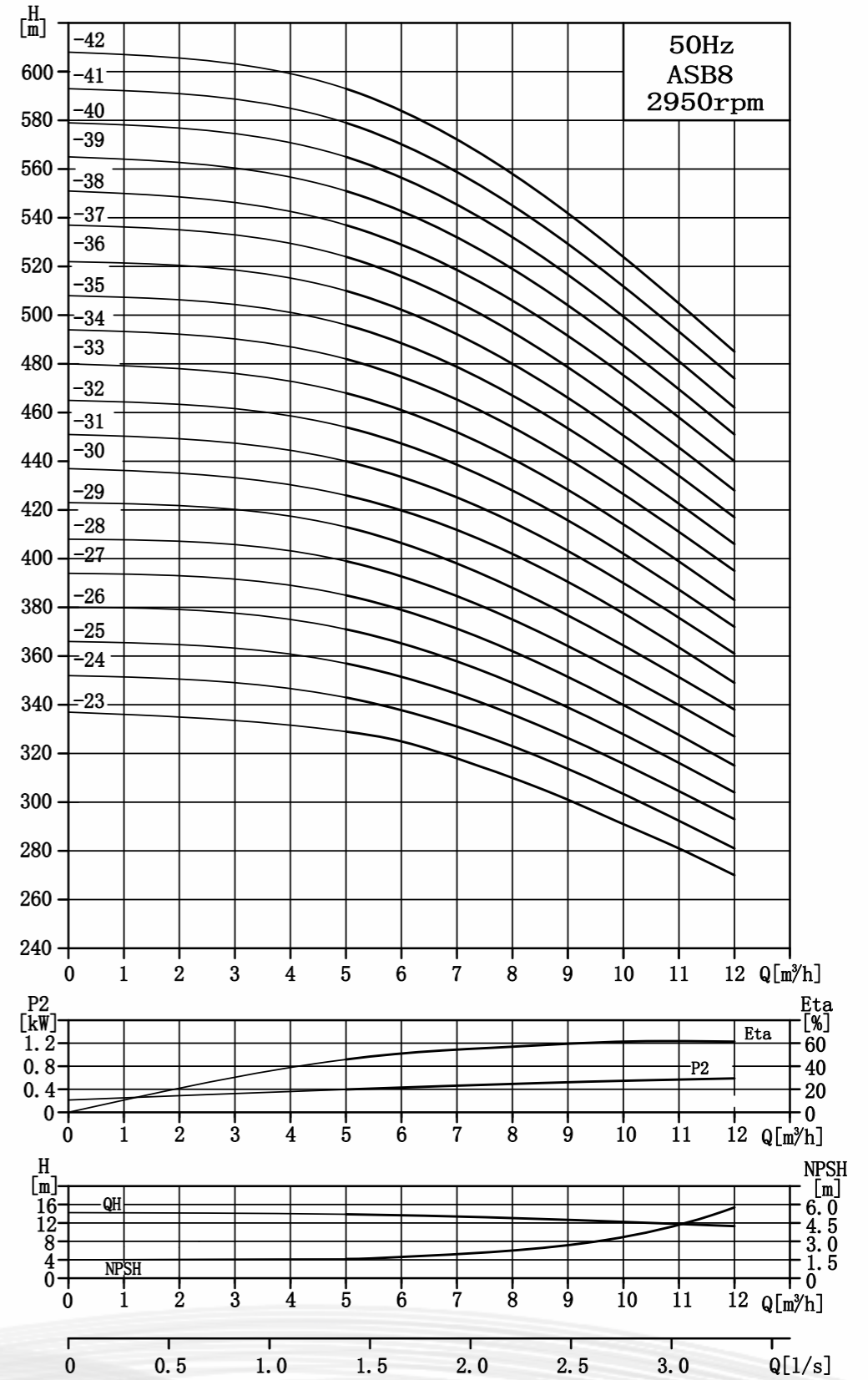

Installation dimensions and weight

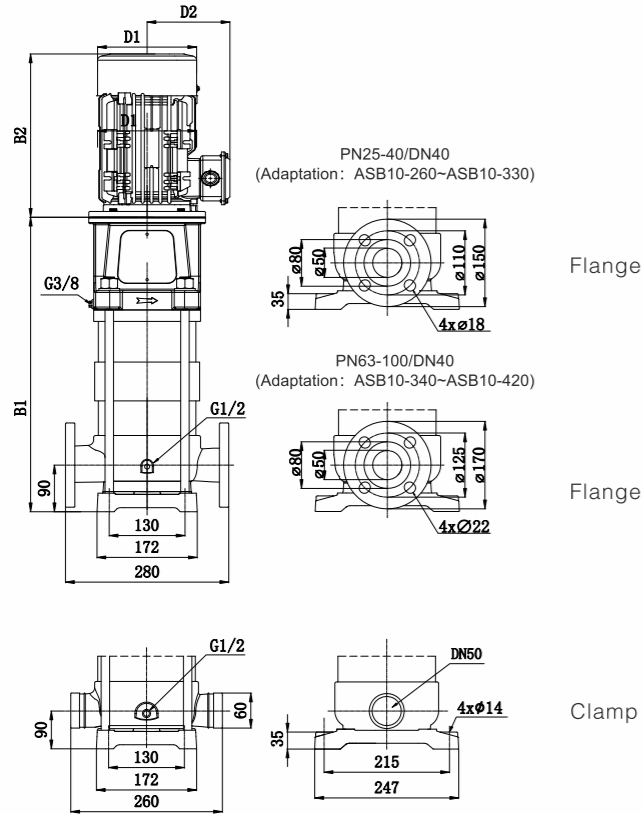

Model	Dimension(mm)					Weight (kg)
	B1	B2	B1+B2	D1	D2	
ASB10-260	1277	523	1800	311	235	188
ASB10-270	1307	523	1830	311	235	189
ASB10-280	1337	578	1915	311	235	213
ASB10-290	1367	578	1945	311	235	215
ASB10-300	1397	578	1975	311	235	216
ASB10-310	1427	578	2005	311	235	218
ASB10-320	1457	578	2035	311	235	220
ASB10-330	1487	578	2065	311	235	221
ASB10-340	1517	578	2095	311	235	255
ASB10-350	1547	578	2125	311	235	257
ASB10-360	1577	578	2155	311	235	258
ASB10-370	1607	578	2185	311	235	260
ASB10-380	1637	578	2215	311	235	261
ASB10-390	1667	578	2245	311	235	263
ASB10-400	1722	666	2388	397	305	333
ASB10-410	1752	666	2418	397	305	334
ASB10-420	1782	666	2448	397	305	336

Performance data

Model	Power(kW)	Q (m³/h)	H (m)									
			5.0	6.0	7.0	8.0	9.0	10.0	11.0	12.0	13.0	
ASB10-260	15	H (m)	341	340	335	328	316	302	285	264	239	
ASB10-270	15		355	353	349	341	329	314	296	274	249	
ASB10-280	18.5		368	367	362	354	341	326	307	285	258	
ASB10-290	18.5		382	380	375	367	354	338	319	295	268	
ASB10-300	18.5		395	394	388	380	367	350	330	306	277	
ASB10-310	18.5		409	407	402	393	379	362	341	316	287	
ASB10-320	18.5		422	420	415	406	392	374	353	327	297	
ASB10-330	18.5		436	434	428	419	404	386	364	337	306	
ASB10-340	22		449	447	442	432	417	398	375	348	316	
ASB10-350	22		463	461	455	445	429	410	387	358	325	
ASB10-360	22		476	474	468	458	442	422	398	369	335	
ASB10-370	22		490	488	481	471	454	434	409	379	344	
ASB10-380	22		503	501	495	484	467	446	421	390	354	
ASB10-390	22		517	515	508	497	479	458	432	400	364	
ASB10-400	22		530	528	521	510	492	470	443	411	373	
ASB10-410	30		544	541	534	523	505	482	455	421	383	
ASB10-420	30		557	555	548	536	517	494	466	432	392	

Performance curve

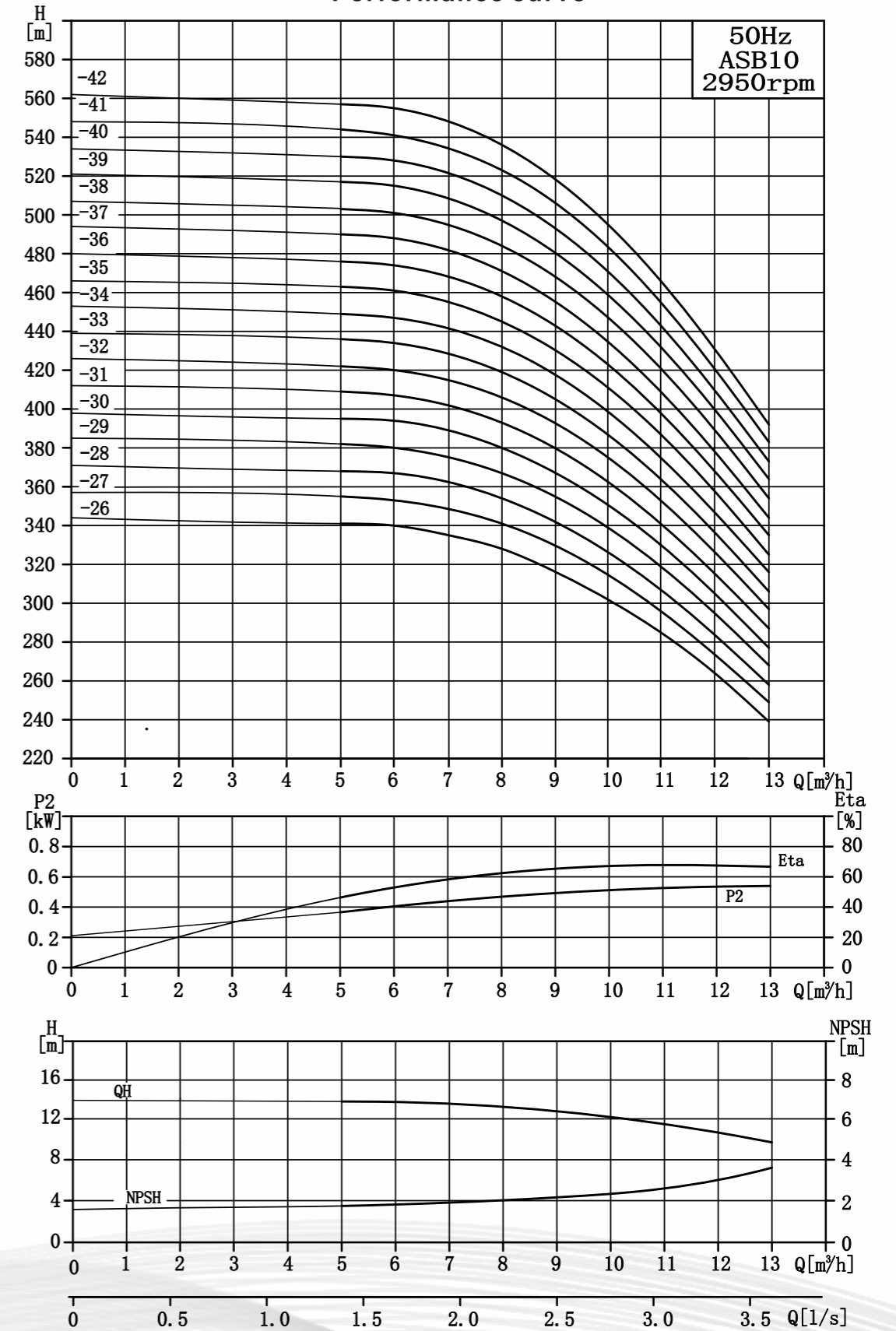

Installation dimensions and weight

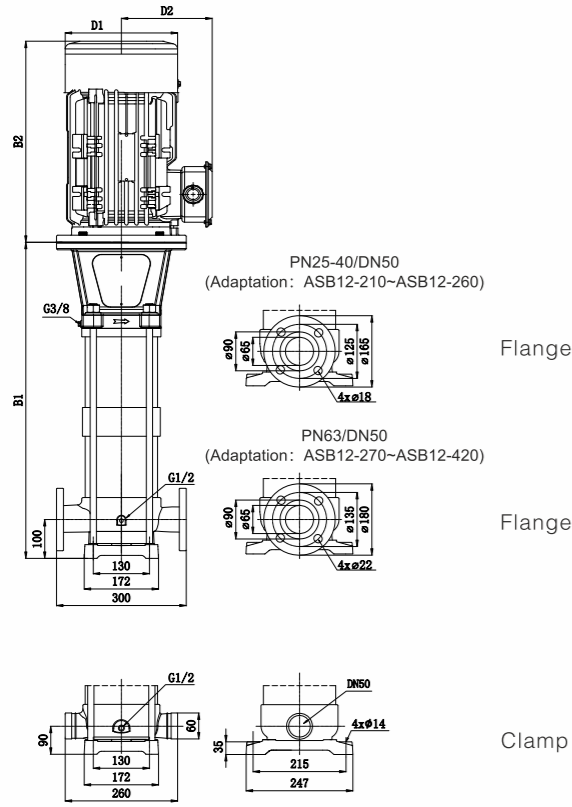

Model	Dimension(mm)					Weight (kg)
	B1	B2	B1+B2	D1	D2	
ASB12-210	1136	578	1714	311	235	239
ASB12-220	1166	578	1744	311	235	240
ASB12-230	1196	578	1774	311	235	242
ASB12-240	1251	666	1917	397	305	312
ASB12-250	1281	666	1947	397	305	314
ASB12-260	1311	666	1977	397	305	315
ASB12-270	1341	666	2007	397	305	317
ASB12-280	1371	666	2037	397	305	319
ASB12-290	1401	666	2067	397	305	320
ASB12-300	1431	666	2097	397	305	322
ASB12-310	1461	666	2127	397	305	324
ASB12-320	1491	666	2157	397	305	339
ASB12-330	1521	666	2187	397	305	341
ASB12-340	1551	666	2217	397	305	343
ASB12-350	1581	666	2247	397	305	345
ASB12-360	1611	666	2277	397	305	346
ASB12-370	1641	666	2307	397	305	348
ASB12-380	1671	666	2337	397	305	350
ASB12-390	1701	666	2367	397	305	351
ASB12-400	1731	666	2397	397	305	353
ASB12-410	1761	704	2465	442	324	422
ASB12-420	1791	704	2495	442	324	423

Performance data

Model	Power(kW)	Q (m³/h)	H (m)									
			7	8	9	10	11	12	13	14	15	16
ASB12-210	22		337	333	329	325	320	314	306	298	287	275
ASB12-220	22		353	349	345	340	335	329	321	313	301	288
ASB12-230	22		369	365	360	356	350	344	336	327	314	302
ASB12-240	22		385	381	376	371	366	359	350	341	328	315
ASB12-250	30		401	397	392	387	381	374	365	355	342	328
ASB12-260	30		417	412	407	402	396	389	379	369	355	341
ASB12-270	30		433	428	423	417	411	404	394	384	369	354
ASB12-280	30		449	444	439	433	426	419	409	398	383	367
ASB12-290	30		465	460	454	448	442	434	423	412	396	380
ASB12-300	30		481	476	470	464	457	449	438	426	410	393
ASB12-310	30		497	492	486	479	472	463	452	441	424	406
ASB12-320	30		513	508	501	495	487	478	467	455	437	420
ASB12-330	37		529	523	517	510	503	493	481	469	451	433
ASB12-340	37		545	539	533	526	518	508	496	483	465	446
ASB12-350	37		561	555	548	541	533	523	511	497	478	459
ASB12-360	37		577	571	564	557	548	538	525	512	492	472
ASB12-370	37		593	587	580	572	564	553	540	526	506	485
ASB12-380	37		609	603	595	587	579	568	554	540	519	498
ASB12-390	37		625	619	611	603	594	583	569	554	533	511
ASB12-400	37		641	634	627	618	609	598	584	568	547	524
ASB12-410	45		657	650	642	634	624	613	598	583	560	538
ASB12-420	45		673	666	658	649	640	628	613	597	574	551

Performance curve

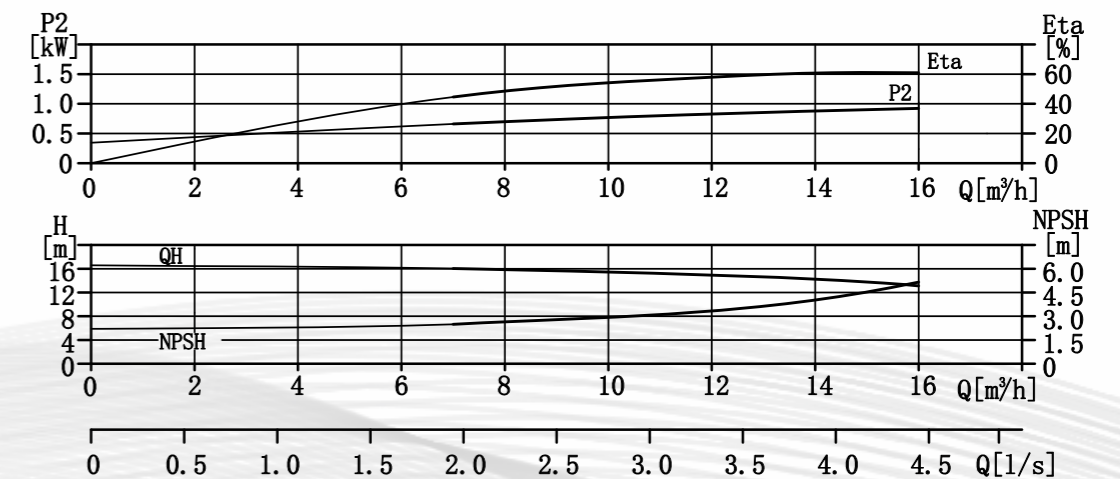
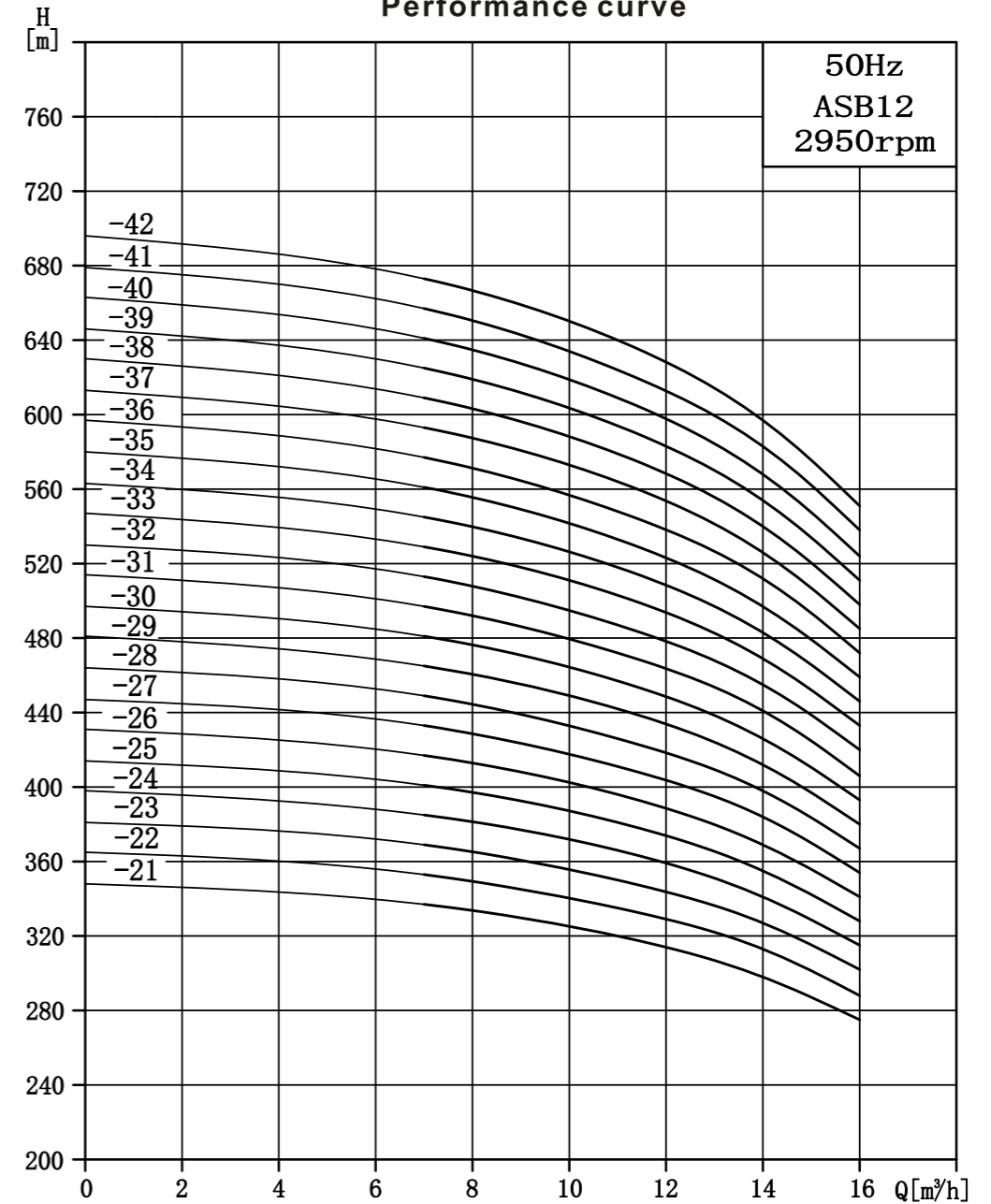

Installation dimensions and weight

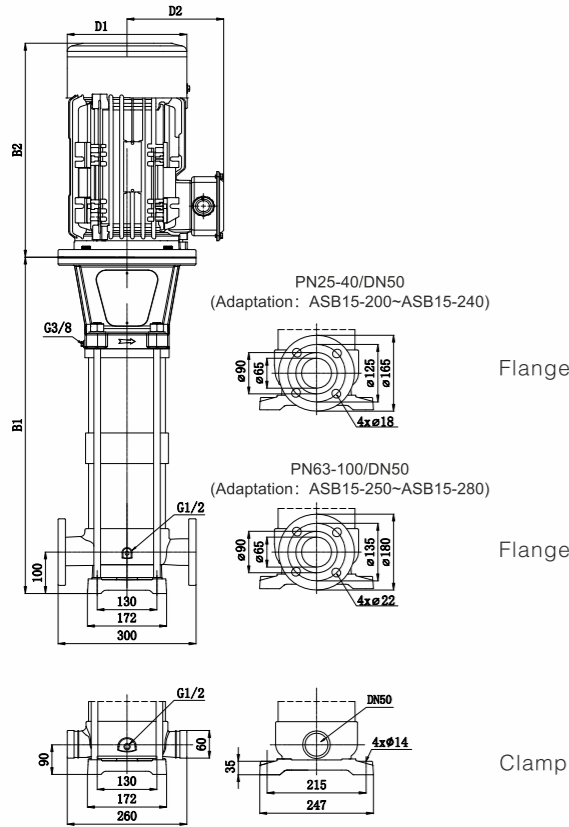

Model	Dimension(mm)					Weight (kg)
	B1	B2	B1+B2	D1	D2	
ASB15-200	1431	666	2097	397	305	309
ASB15-210	1476	666	2142	397	305	310
ASB15-220	1521	666	2187	397	305	311
ASB15-230	1566	666	2232	397	305	312
ASB15-240	1611	666	2277	397	305	313
ASB15-250	1656	666	2322	397	305	314
ASB15-260	1701	666	2367	397	305	329
ASB15-270	1746	666	2412	397	305	330
ASB15-280	1791	666	2457	397	305	331

Performance data

Model	Power(kW)	Q (m³/h)	H (m)									
			8	10	12	14	15	16	18	20	23	
ASB15-200	30	H (m)	344	339	333	326	321	317	307	297	281	
ASB15-210	30		361	356	350	342	337	333	323	312	295	
ASB15-220	30		379	373	367	358	353	348	338	327	309	
ASB15-230	30		396	390	383	374	369	364	353	342	323	
ASB15-240	30		413	407	400	391	385	380	369	356	337	
ASB15-250	30		430	424	417	407	402	396	384	371	351	
ASB15-260	37		447	441	433	423	418	412	399	386	365	
ASB15-270	37		465	458	450	440	434	428	415	401	379	
ASB15-280	37		482	475	466	456	450	444	430	416	393	

Performance curve

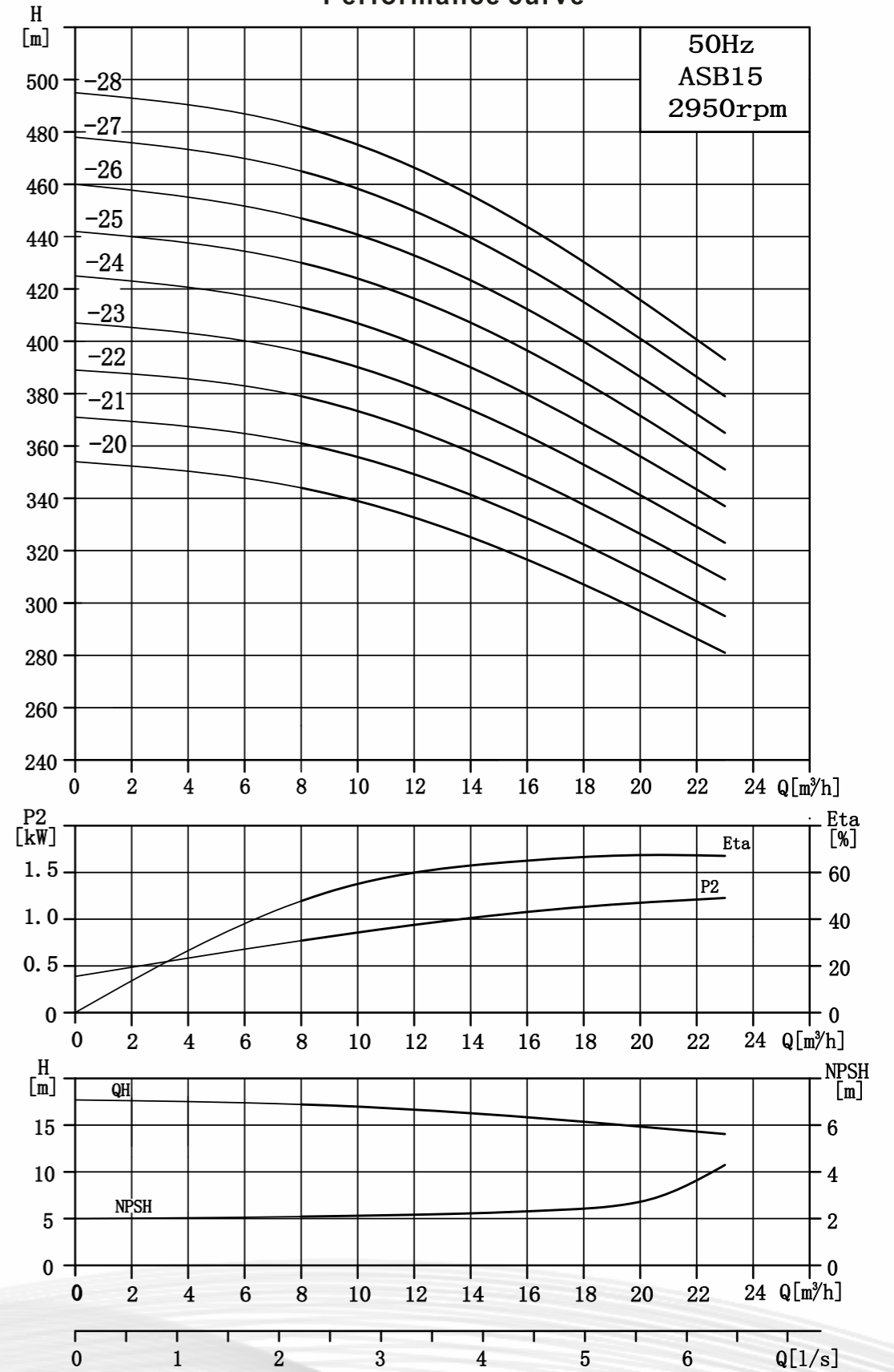

Installation dimensions and weight

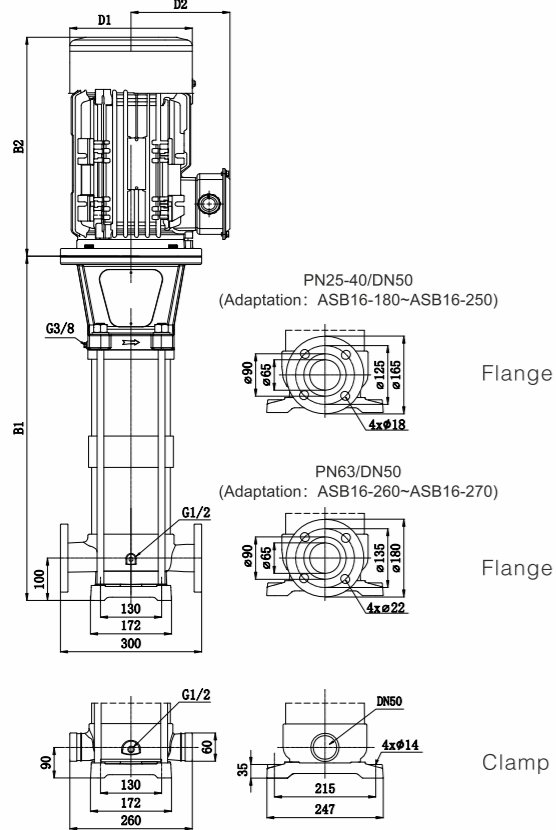

Model	Dimension(mm)					Weight (kg)
	B1	B2	B1+B2	D1	D2	
ASB16-180	1341	666	2007	397	305	306
ASB16-190	1386	666	2052	397	305	307
ASB16-200	1431	666	2097	397	305	308
ASB16-210	1476	666	2142	397	305	309
ASB16-220	1521	666	2187	397	305	310
ASB16-230	1566	666	2232	397	305	311
ASB16-240	1611	666	2277	397	305	326
ASB16-250	1656	666	2322	397	305	327
ASB16-260	1701	666	2367	397	305	328
ASB16-270	1746	666	2412	397	305	329

Performance data

Model	Power(kW)	Q (m³/h)	H (m)							
			8	10	12	14	16	18	20	22
ASB16-180	30	H (m)	308	303	299	294	288	282	274	266
ASB16-190	30		325	320	315	310	304	297	290	281
ASB16-200	30		342	337	332	326	320	313	305	296
ASB16-210	30		359	354	348	343	336	328	320	311
ASB16-220	30		376	371	365	359	352	344	335	325
ASB16-230	30		393	388	382	375	368	360	350	340
ASB16-240	37		410	404	398	392	384	375	366	355
ASB16-250	37		427	421	415	408	400	391	381	370
ASB16-260	37		444	438	431	424	416	407	396	385
ASB16-270	37	462	455	448	441	432	422	411	399	

Performance curve

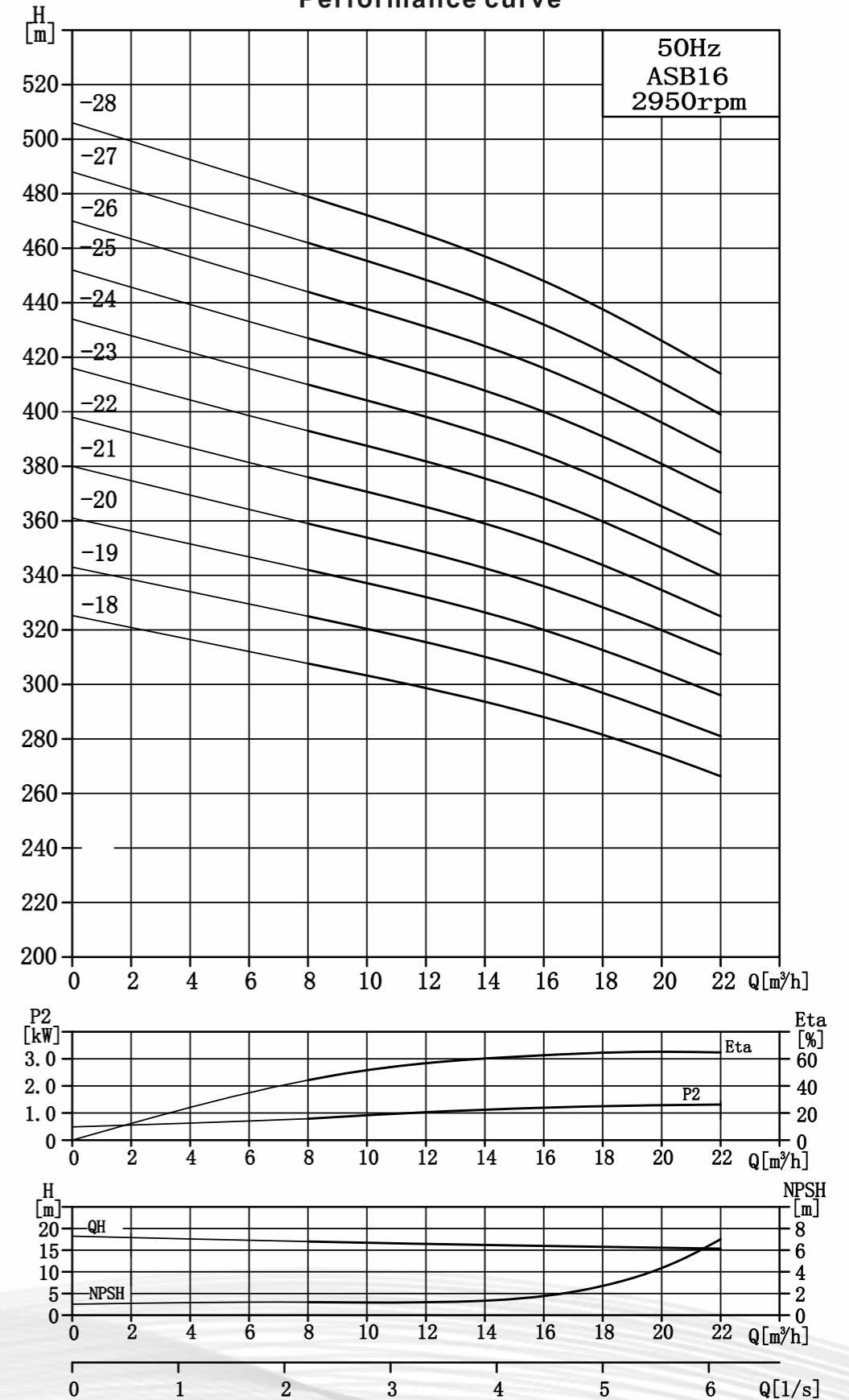

Installation dimensions and weight

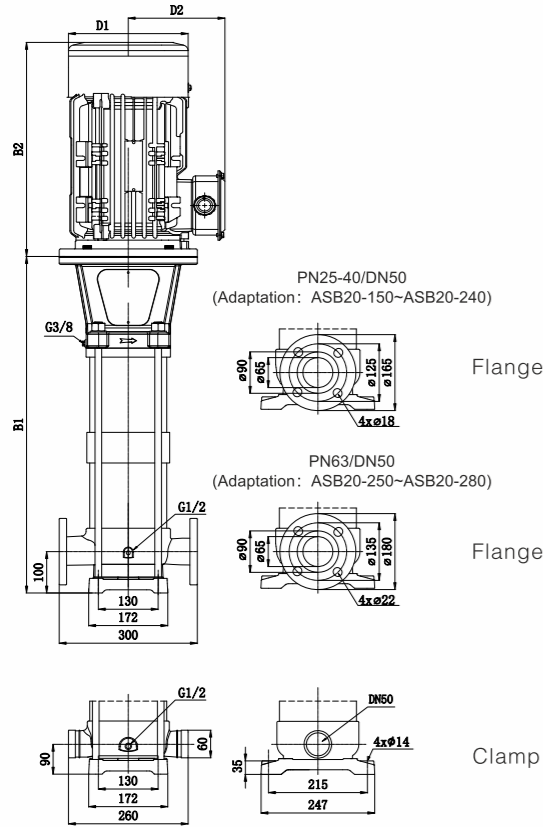

Model	Dimension(mm)					Weight (kg)
	B1	B2	B1+B2	D1	D2	
ASB20-150	1206	666	1872	397	305	313
ASB20-160	1251	666	1917	397	305	314
ASB20-170	1296	666	1962	397	305	315
ASB20-180	1341	666	2007	397	305	316
ASB20-190	1386	666	2052	397	305	331
ASB20-200	1431	666	2097	397	305	332
ASB20-210	1476	666	2142	397	305	333
ASB20-220	1521	666	2187	397	305	334
ASB20-230	1566	666	2232	397	305	335
ASB20-240	1611	666	2277	397	305	336
ASB20-250	1656	666	2322	397	305	337
ASB20-260	1701	704	2405	442	324	405
ASB20-270	1746	704	2450	442	324	406
ASB20-280	1791	704	2495	442	324	407

Performance data

Model	Power(kW)	Q (m³/h)	H (m)											
			10	12	14	16	18	20	22	24	26	28		
ASB20-150	22		257	254	251	247	241	234	224	212	200	186		
ASB20-160	30		274	271	268	263	257	249	239	227	213	199		
ASB20-170	30		291	288	284	280	273	265	254	241	226	211		
ASB20-180	30		308	305	301	296	289	280	269	255	239	223		
ASB20-190	30		325	322	318	313	306	296	284	269	253	236		
ASB20-200	30		342	339	335	329	322	312	299	283	266	248		
ASB20-210	37		359	356	351	346	338	327	314	297	279	261		
ASB20-220	37		376	373	368	362	354	343	328	312	293	273		
ASB20-230	37		394	390	385	379	370	358	343	326	306	285		
ASB20-240	37		411	407	402	395	386	374	358	340	319	298		
ASB20-250	37		428	424	418	412	402	390	373	354	333	310		
ASB20-260	45		445	440	435	428	418	405	388	368	346	323		
ASB20-270	45		462	457	452	444	434	421	403	382	359	335		
ASB20-280	45		479	474	468	461	450	436	418	396	372	347		

Performance curve

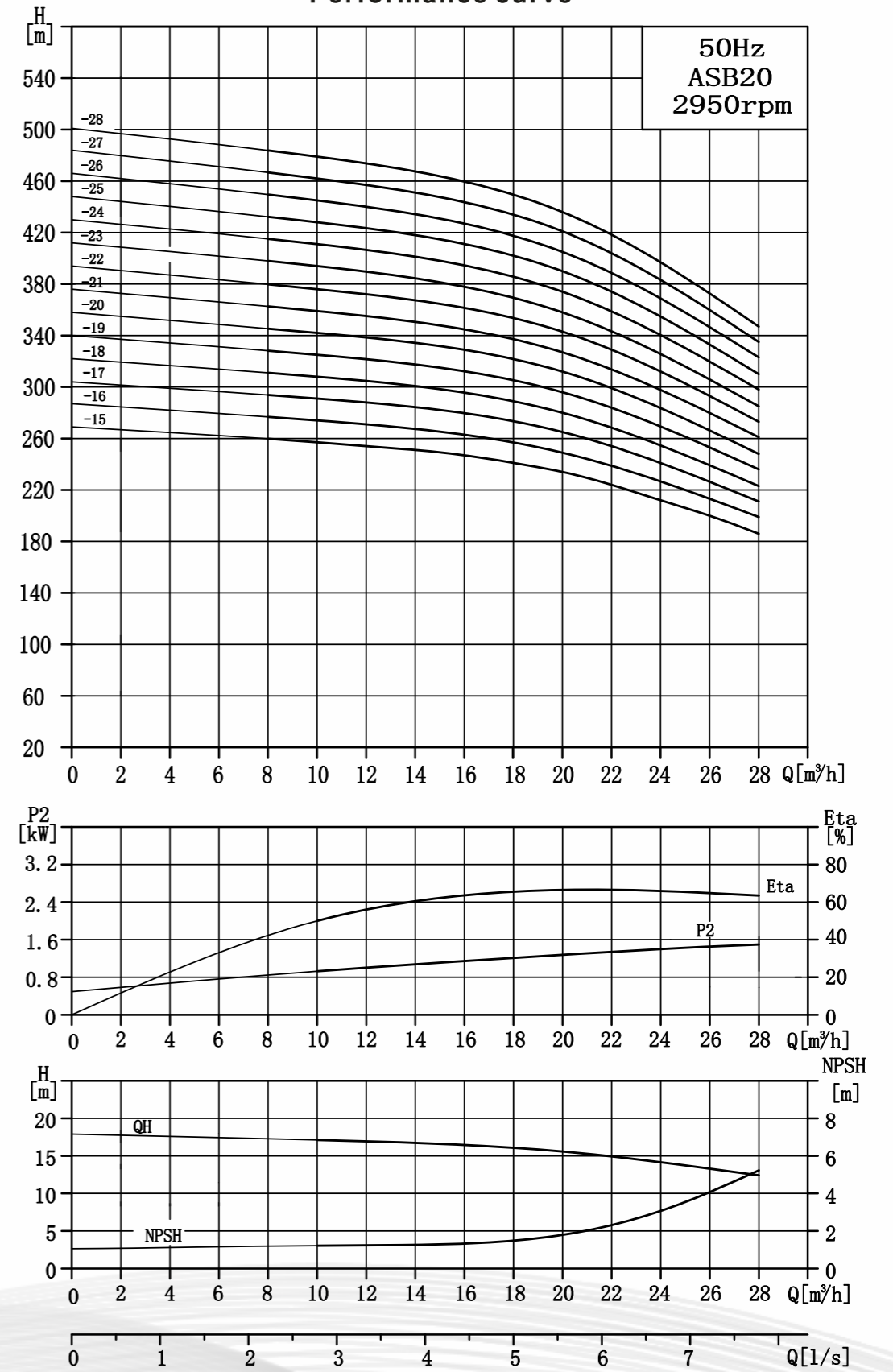

Installation dimensions and weight

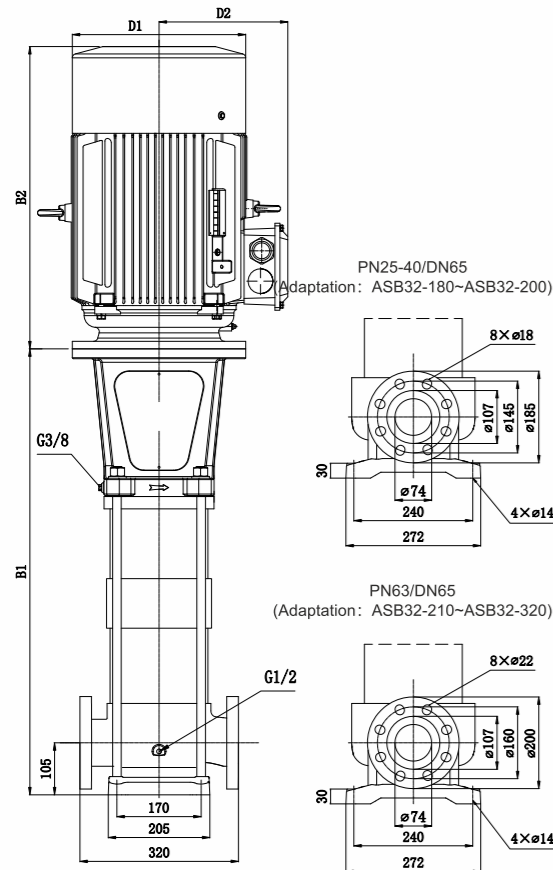

Model	Dimension(mm)					Weight (kg)
	B1	B2	B1+B2	D1	D2	
ASB32-180	1884	704	2588	442	324	435
ASB32-190	1984	785	2769	484	365	523
ASB32-200	2054	785	2839	484	365	525
ASB32-210	2124	849	2973	548	388	641
ASB32-220	2194	849	3043	548	388	643
ASB32-230	2264	849	3113	548	388	645
ASB32-240	2334	849	3183	548	388	647
ASB32-250	2404	849	3253	548	388	649
ASB32-260	2474	849	3323	548	388	651
ASB32-270	2544	849	3393	548	388	653
ASB32-280	2614	849	3463	548	388	701
ASB32-290	2684	849	3533	548	388	703
ASB32-300	2754	849	3603	548	388	705
ASB32-310	2824	849	3673	548	388	707
ASB32-320	2894	900	3794	548	388	709

Performance data

Model	Power(kW)	Q (m³/h)	H (m)									
			16	20	24	28	32	36	40	42		
ASB32-180	45		399	389	374	356	334	311	287	274		
ASB32-190	55		420	409	394	374	352	327	302	288		
ASB32-200	55		441	430	413	393	369	344	316	303		
ASB32-210	55		462	450	433	412	387	360	331	317		
ASB32-220	55		483	471	453	430	404	376	346	331		
ASB32-230	75		504	491	472	449	422	392	361	345		
ASB32-240	75		525	512	492	468	439	408	376	359		
ASB32-250	75		547	532	512	486	457	425	391	373		
ASB32-260	75		568	552	531	505	474	441	405	387		
ASB32-270	75		589	573	551	524	492	457	420	402		
ASB32-280	75		610	593	571	542	509	473	435	416		
ASB32-290	75		631	614	590	561	527	489	450	430		
ASB32-300	75		652	634	610	580	544	505	465	444		
ASB32-310	75		673	655	630	598	562	522	479	458		
ASB32-320	90		694	675	649	617	579	538	494	472		

Performance curve

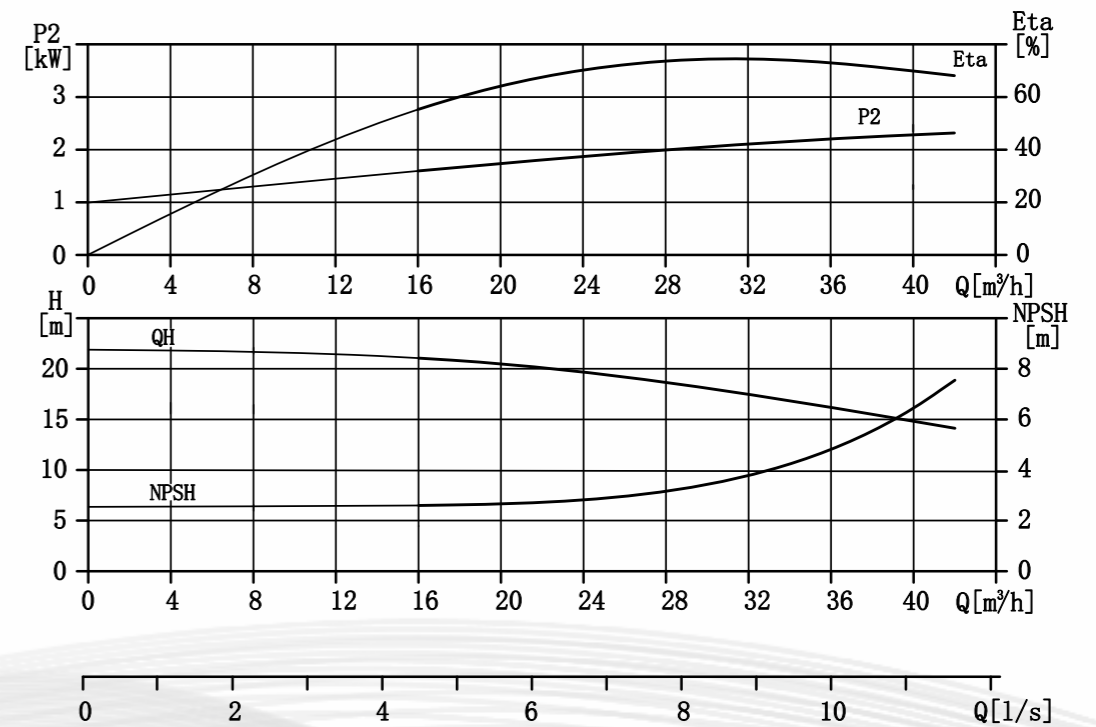
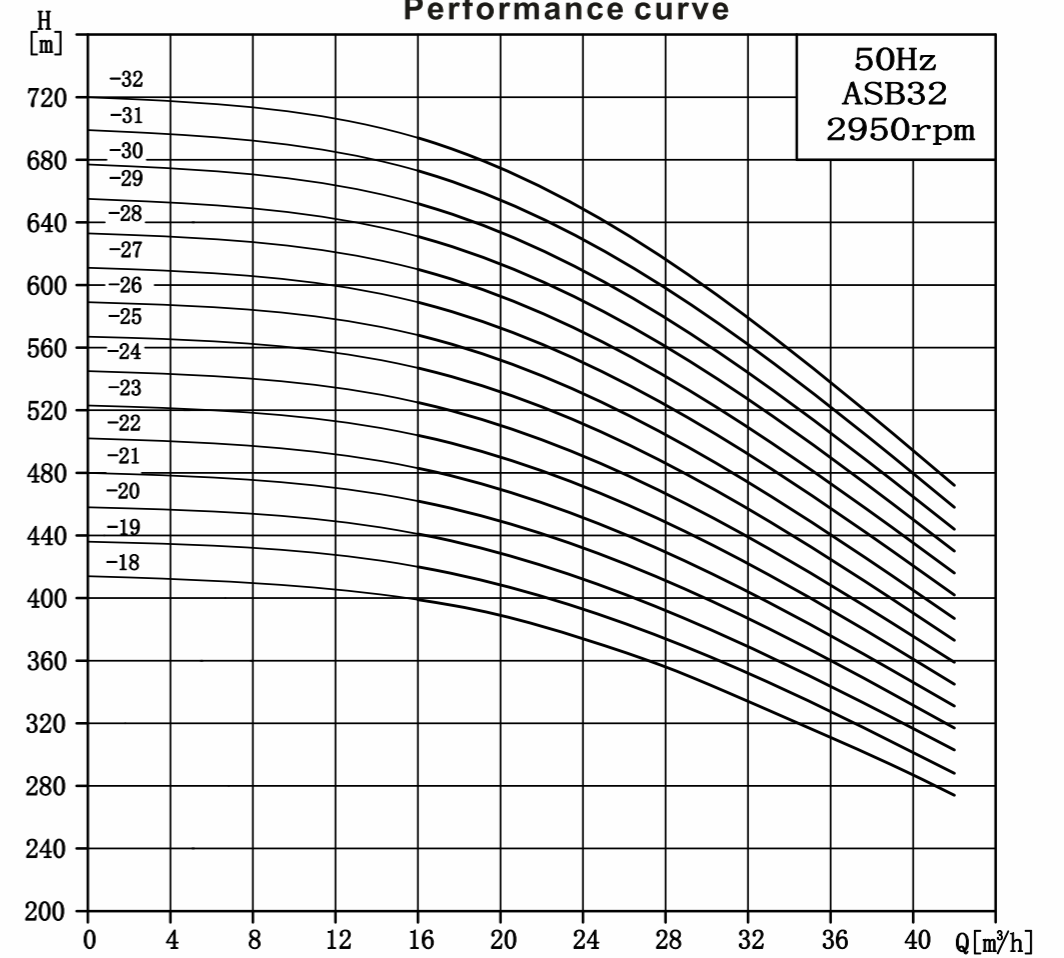

Installation dimensions and weight

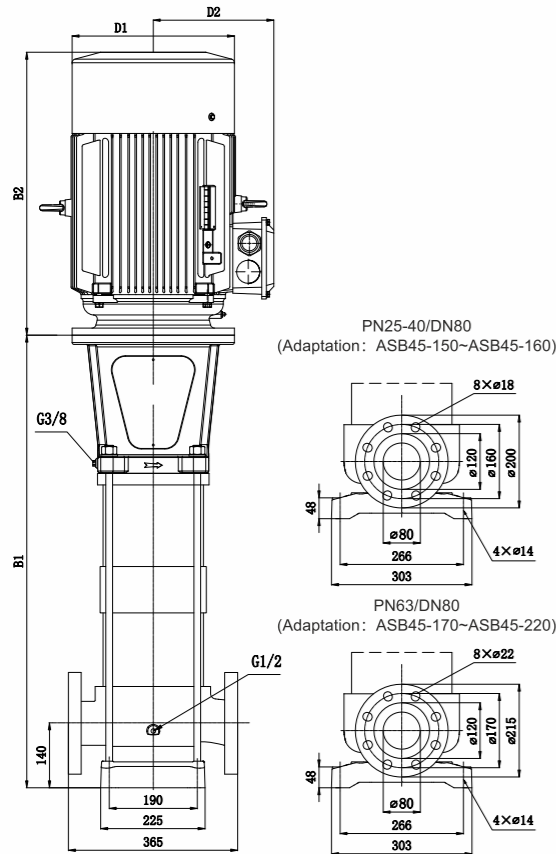

Model	Dimension(mm)					Weight (kg)
	B1	B2	B1+B2	D1	D2	
ASB45-150	1902	849	2751	548	388	670
ASB45-160	1982	849	2831	548	388	672
ASB45-170	2062	849	2911	548	388	674
ASB45-180	2142	849	2991	548	388	676
ASB45-190	2222	900	3122	548	388	724
ASB45-200	2302	900	3202	548	388	726

Performance data

Model	Power(kW)	Q (m³/h)	H (m)						
			25	30	35	40	45	50	55
ASB45-150	75	H (m)	395	387	377	364	349	333	317
ASB45-160	75		421	413	401	387	372	355	337
ASB45-170	75		447	438	426	411	394	376	357
ASB45-180	75		472	463	450	435	417	398	378
ASB45-190	90		498	488	475	458	439	419	398
ASB45-200	90		524	513	499	482	462	441	419

Performance curve

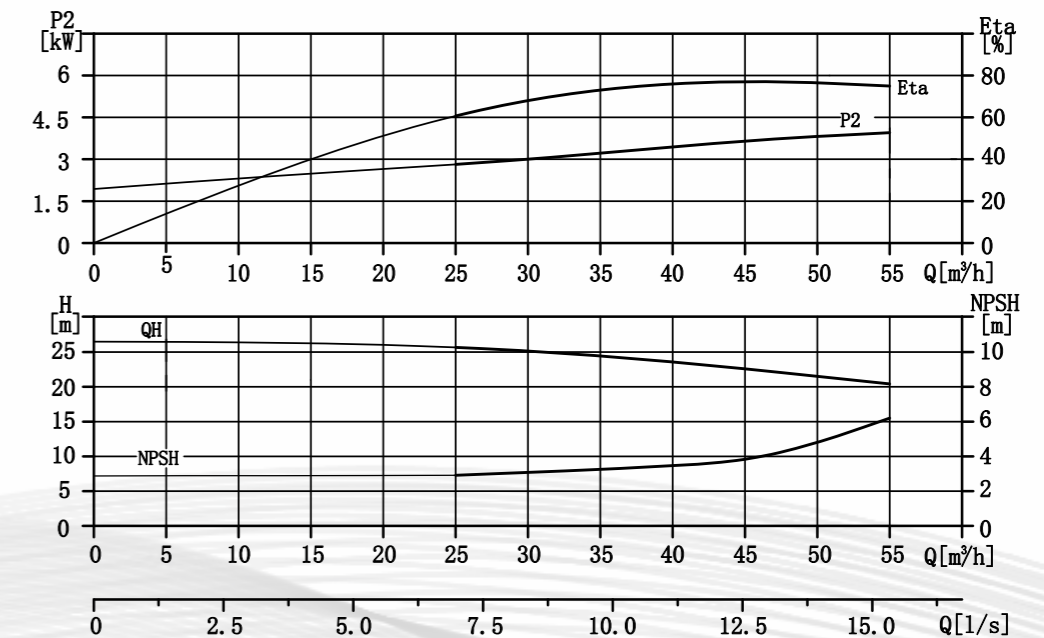
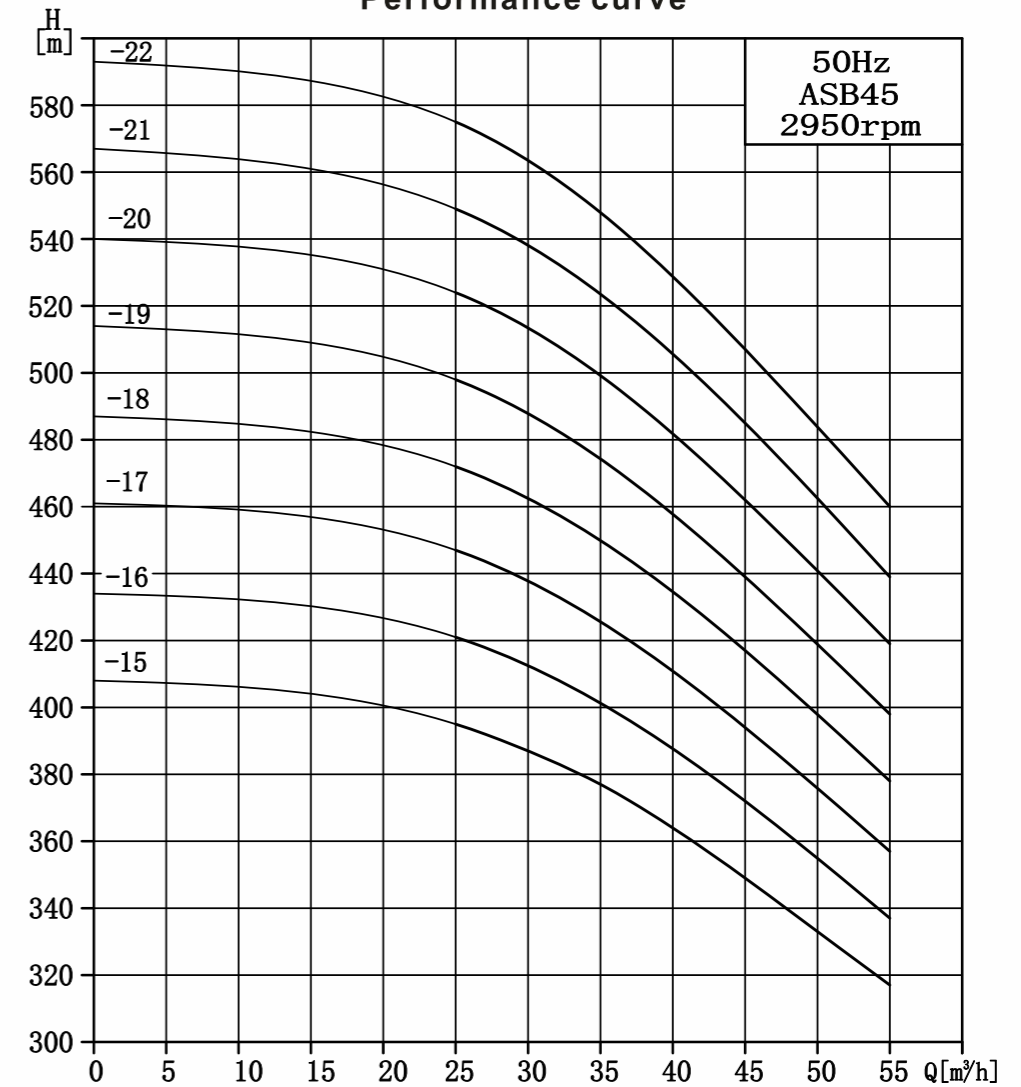

Installation dimensions and weight

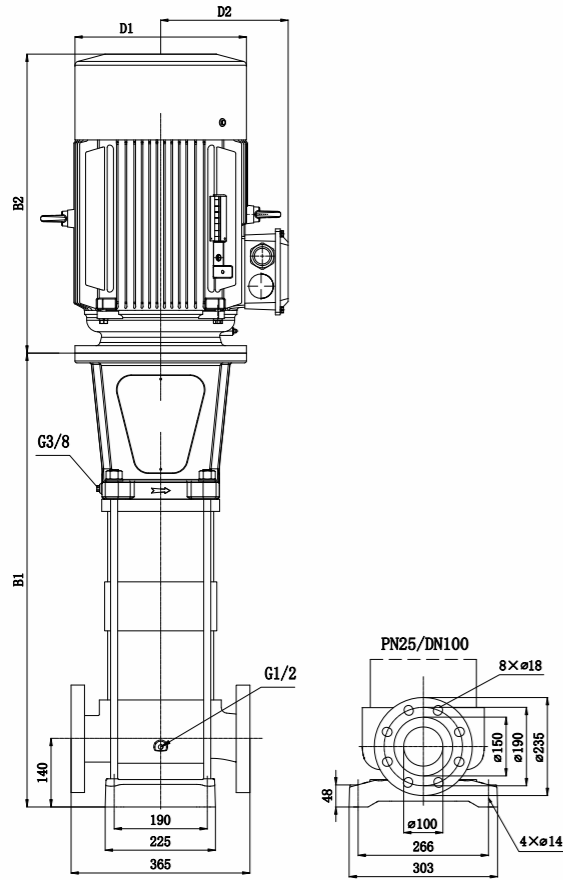

Model	Dimension(mm)					Weight (kg)
	B1	B2	B1+B2	D1	D2	
ASB64-70-2	1285	785	2070	484	365	520
ASB64-70	1285	785	2070	484	365	520
ASB64-80-2	1368	785	2153	484	365	523
ASB64-80	1368	785	2153	484	365	523
ASB64-90-2	1451	849	2300	548	388	640
ASB64-90	1451	849	2300	548	388	640
ASB64-100-2	1534	849	2383	548	388	643
ASB64-100	1534	849	2383	548	388	643
ASB64-110	1617	900	2517	548	388	673
ASB64-120	1700	900	2600	548	388	696

Performance data

Model	Power(kW)	Q (m³/h)	H (m)						
			30	40	50	60	64	70	80
ASB64-70-2	55	H (m)	203	199	191	181	176	167	150
ASB64-70	55		210	207	201	193	189	182	168
ASB64-80-2	55		233	229	220	208	203	193	174
ASB64-80	55		240	237	230	220	216	208	192
ASB64-90-2	75		261	258	250	239	233	222	199
ASB64-90	75		271	268	261	250	245	235	217
ASB64-100-2	75		292	288	280	268	260	248	225
ASB64-100	75		301	298	290	279	272	263	243
ASB64-110	90		331	325	317	305	299	288	267
ASB64-120	90		361	355	346	333	326	314	291

Performance curve

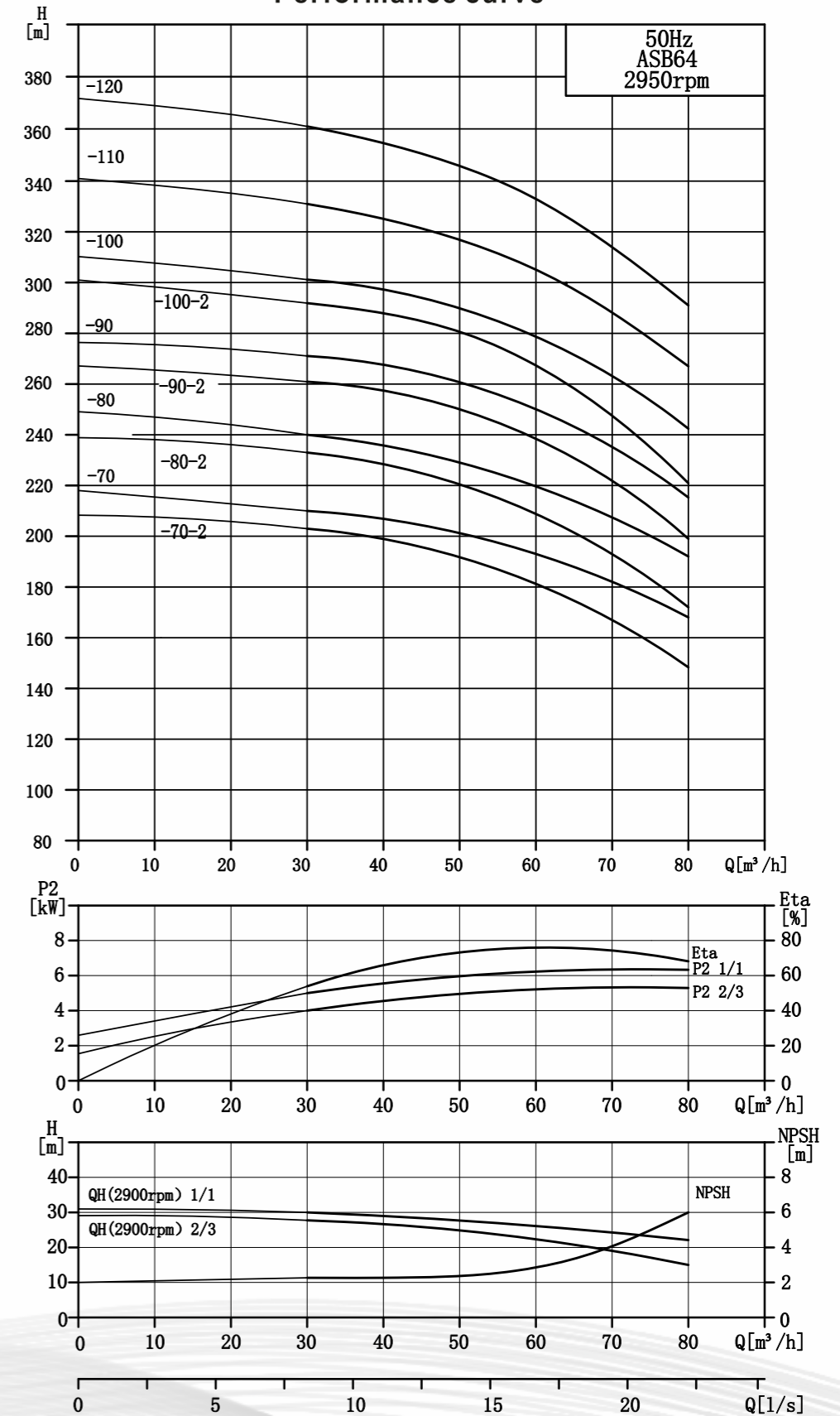

Installation dimensions and weight

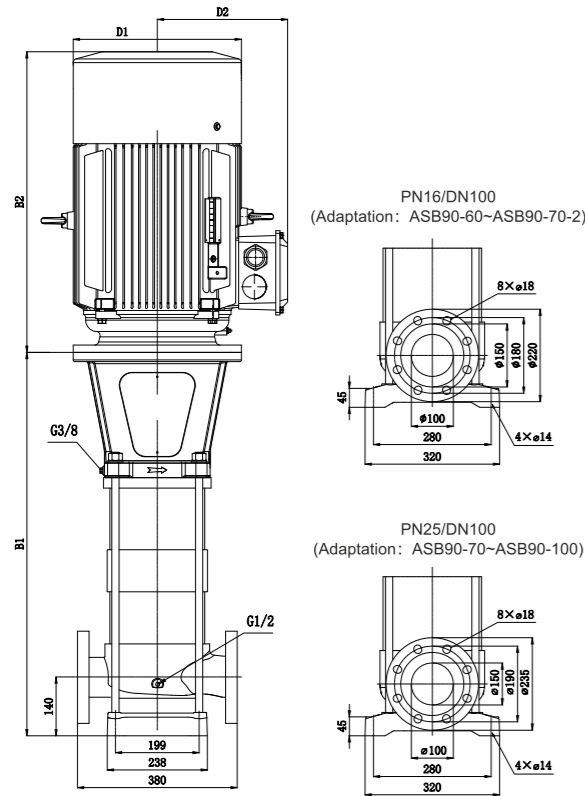

Model	Dimension(mm)					Weight (kg)
	B1	B2	B1+B2	D1	D2	
ASB90-60	1258	785	2043	484	365	524
ASB90-70-2	1350	785	2135	484	365	527
ASB90-70	1350	849	2199	548	388	641
ASB90-80-2	1442	849	2291	548	388	644
ASB90-80	1442	849	2291	548	388	644
ASB90-90-2	1534	849	2383	548	388	647
ASB90-90	1534	849	2383	548	388	647
ASB90-100	1626	900	2526	548	388	697

Performance data

Model	Power(kW)	Q (m³/h)	H (m)							
			20	50	60	70	80	90	100	110
ASB90-60	55	H (m)	196	174	173	164	154	144	132	119
ASB90-70-2	55		214	198	190	184	172	160	146	128
ASB90-70	75		230	209	201	191	181	167	153	138
ASB90-80-2	75		246	226	217	208	197	183	166	148
ASB90-80	75		261	238	228	217	205	191	175	158
ASB90-90-2	75		278	255	246	235	222	206	188	167
ASB90-90	75		293	268	257	244	230	214	196	177
ASB90-100	90		326	298	286	271	256	238	218	197

Performance curve

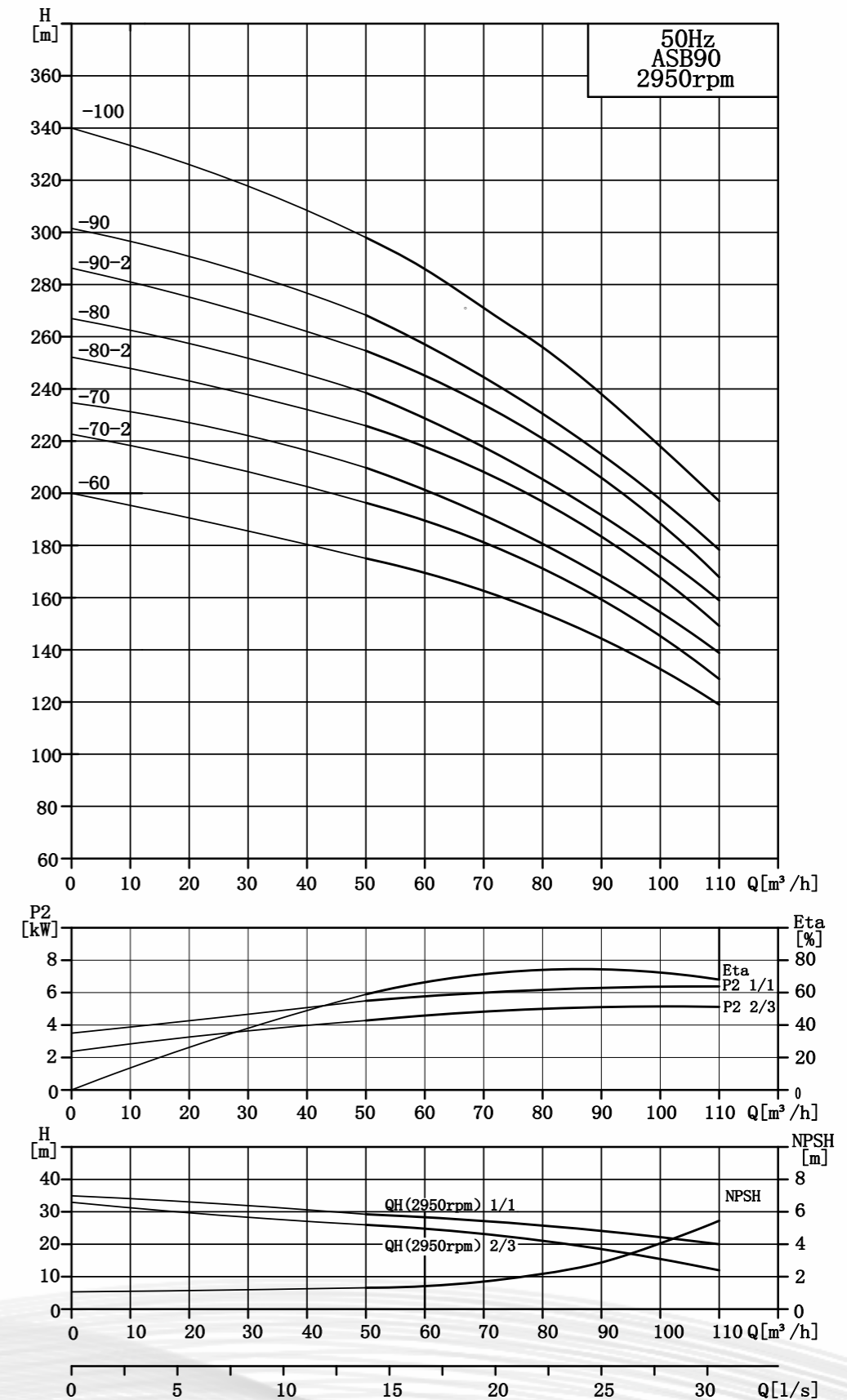

Installation dimensions and weight

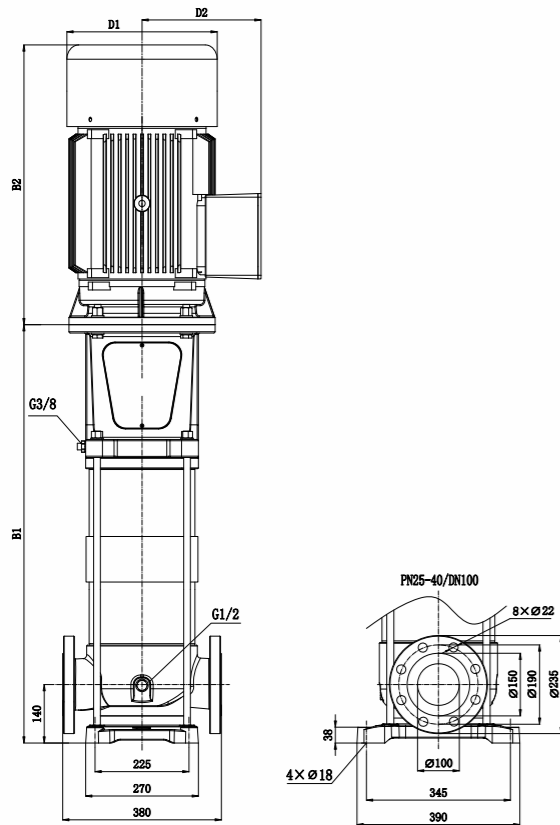

Model	Dimension(mm)					Weight (kg)
	B1	B2	B1+B2	D1	D2	
ASB100-70-2	1478	785	2263	484	365	545
ASB100-70	1478	785	2263	484	365	545
ASB100-80-2	1582	785	2367	484	365	550
ASB100-80	1582	849	2431	548	388	665
ASB100-90-2	1687	849	2536	548	388	670
ASB100-90	1687	849	2536	548	388	670
ASB100-100-2	1791	849	2640	548	388	676
ASB100-100	1791	849	2640	548	388	676
ASB100-110	1896	900	2796	548	388	726
ASB100-120	2000	900	2900	548	388	726

Performance data

Model	Power(kW)	Q (m³/h)	H (m)										
			50	60	70	80	90	100	110	120	125		
ASB100-70-2	55	H (m)	189	184	177	168	156	137	119	97	87		
ASB100-70	55		206	202	193	183	172	156	138	114	105		
ASB100-80-2	55		221	215	207	197	182	165	142	115	103		
ASB100-80	75		235	231	221	209	197	178	158	130	120		
ASB100-90-2	75		250	245	234	221	206	184	161	131	120		
ASB100-90	75		265	260	248	235	221	201	177	147	135		
ASB100-100-2	75		279	274	262	247	231	206	181	147	135		
ASB100-100	75		294	289	279	261	246	223	197	163	150		
ASB100-110	90		323	313	301	287	268	245	216	183	165		
ASB100-120	90		353	341	328	313	292	268	236	200	180		

Performance curve

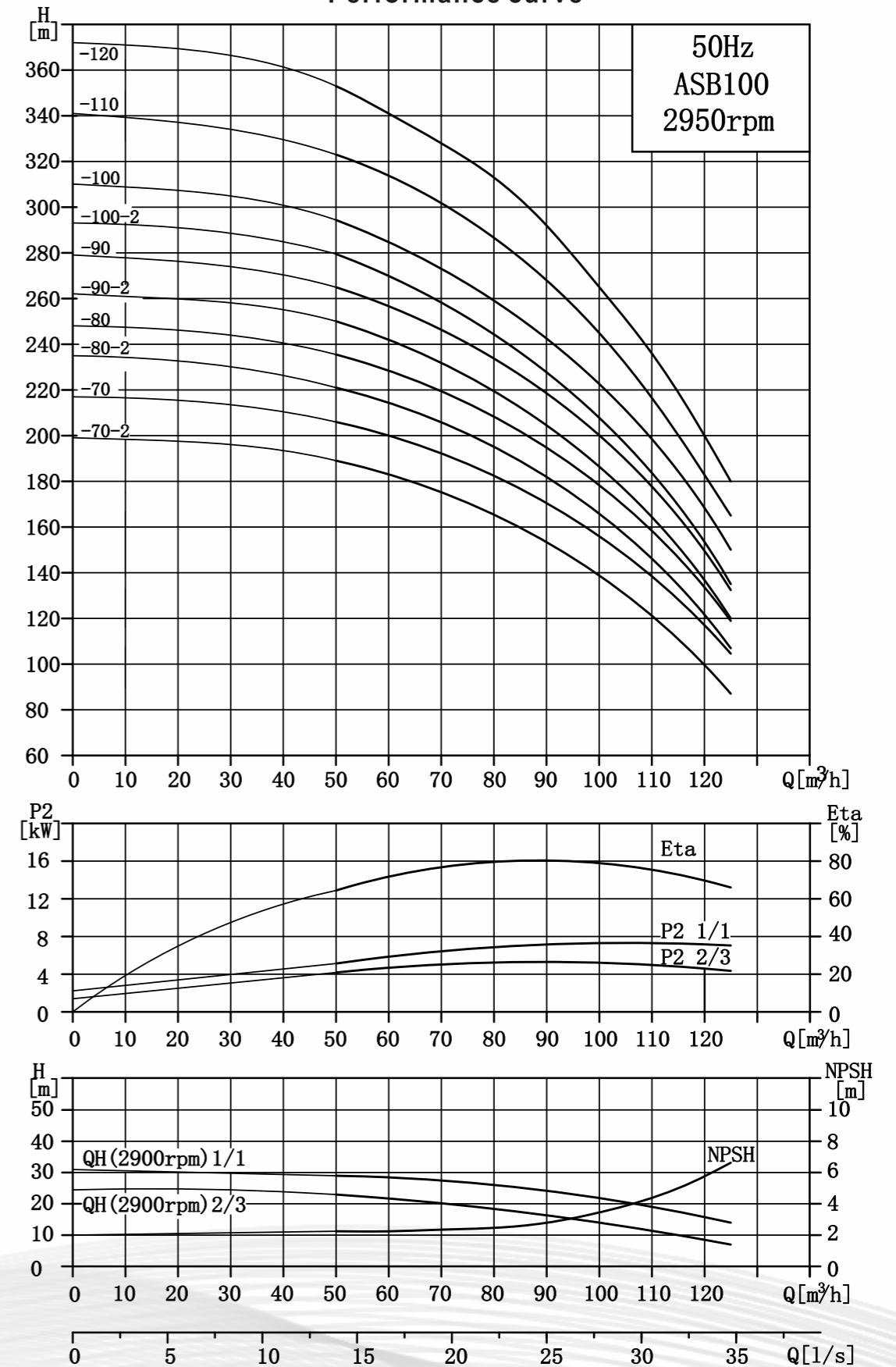

Installation dimensions and weight

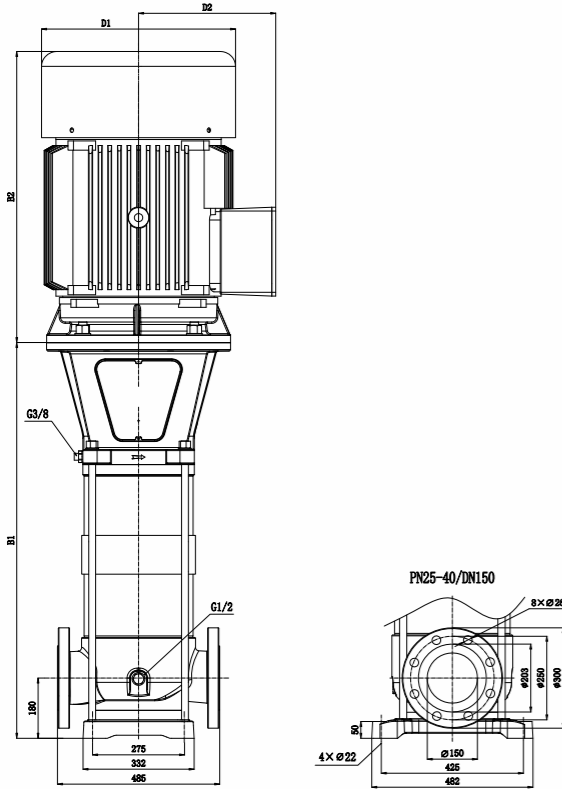

Model	Dimension(mm)					Weight (kg)
	B1	B2	B1+B2	D1	D2	
ASB130-50	1404	785	2189	484	365	585
ASB130-60	1526	849	2375	548	388	708
ASB130-70	1648	849	2497	548	388	717
ASB130-80	1770	900	2670	548	388	772
ASB130-90-2	1892	900	2792	548	388	782
ASB130-90	1892	1190	3082	630	525	1118
ASB130-100	2014	1190	3204	630	525	1127

Performance data

Model	Power(kW)	Q (m³/h)	H (m)												
			60	70	80	90	100	110	120	130	140	150	160		
ASB130-50	55	H (m)	164	162	158	152	147	142	133	124	114	103	91		
ASB130-60	75		198	196	189	182	178	170	161	150	137	122	108		
ASB130-70	75		231	227	222	218	209	199	187	174	159	144	126		
ASB130-80	90		264	260	254	248	238	228	213	200	182	164	144		
ASB130-90-2	90		279	274	269	261	250	239	224	208	188	168	146		
ASB130-90	110		297	293	287	279	268	257	243	227	207	187	164		
ASB130-100	110		331	325	318	311	298	284	270	250	230	207	182		

Performance curve

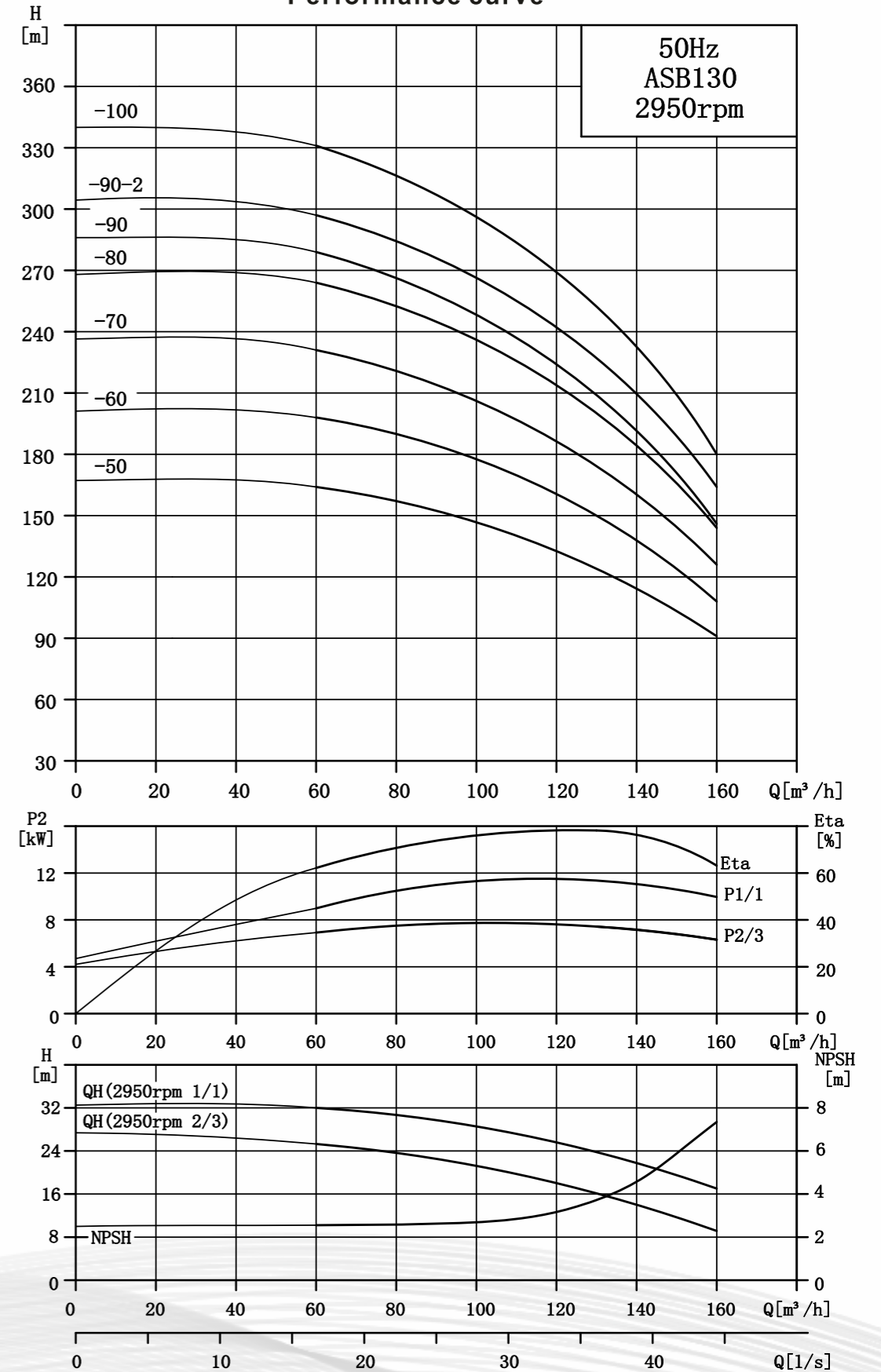

Installation dimensions and weight

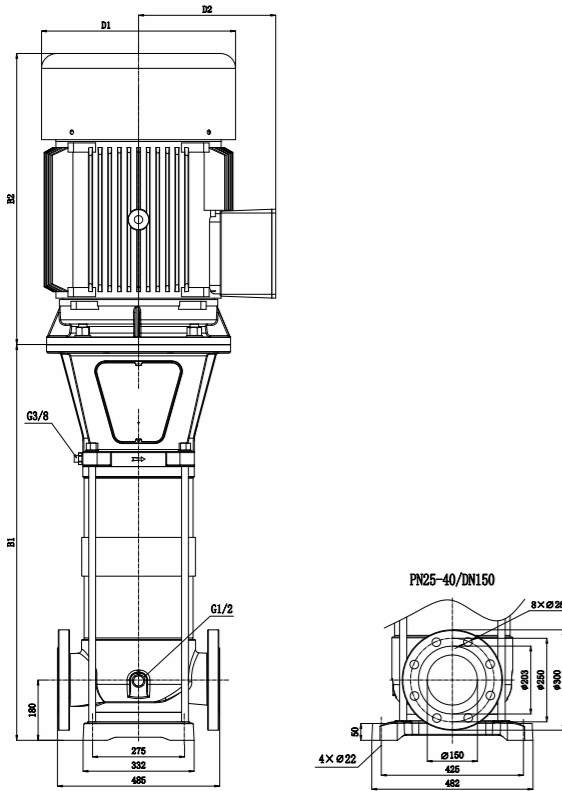

Model	Dimension(mm)					Weight (kg)
	B1	B2	B1+B2	D1	D2	
ASB160-40-2	1282	785	2067	484	365	581
ASB160-40-1	1282	785	2067	484	365	581
ASB160-40	1282	849	2131	548	388	695
ASB160-50-2	1404	849	2253	548	388	700
ASB160-50	1404	849	2253	548	388	700
ASB160-60	1526	900	2426	548	388	756
ASB160-70	1648	1190	2838	630	525	1101
ASB160-80-2	1770	1190	2960	630	525	1110

Performance data

Model	Power(kW)	Q (m³/h)	H (m)													
			80	90	100	110	120	130	140	150	160	170	180	190	200	
ASB160-40-2	55	H (m)	129	124	121	117	112	106	100	94	87	79	71	61	51	
ASB160-40-1	55		136	133	130	126	122	117	112	105	98	90	81	70	60	
ASB160-40	75		142	137	134	131	128	123	118	112	105	97	88	78	67	
ASB160-50-2	75		166	163	159	154	148	142	135	127	118	108	96	83	70	
ASB160-50	75		175	173	171	168	164	158	151	142	133	122	111	97	83	
ASB160-60	90		212	209	205	201	196	190	181	171	159	147	133	115	98	
ASB160-70	110		247	244	241	236	231	222	212	200	188	171	154	135	115	
ASB160-80-2	110		272	267	262	256	249	238	226	213	198	180	161	141	120	

Performance curve

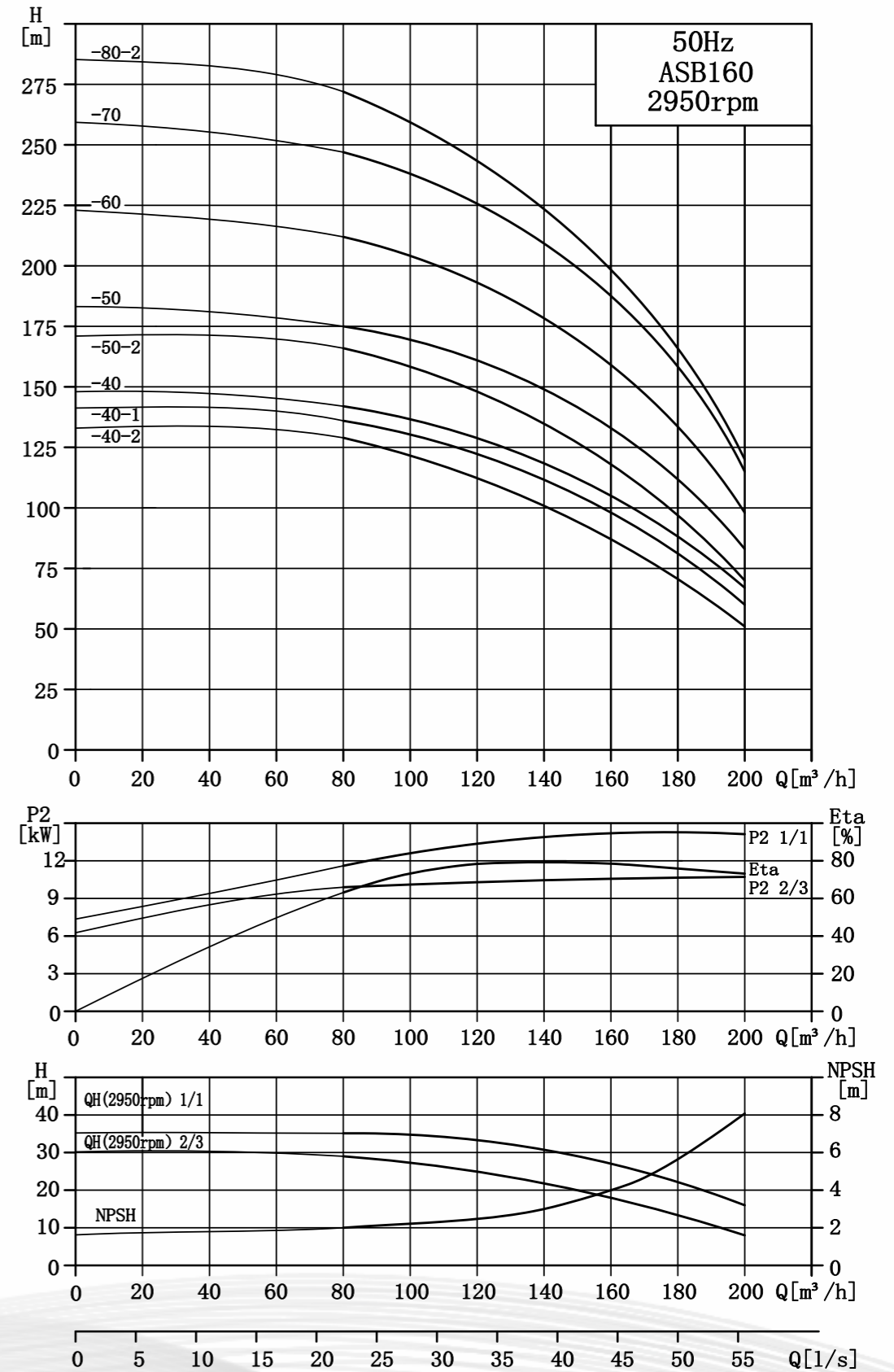

Installation dimensions and weight

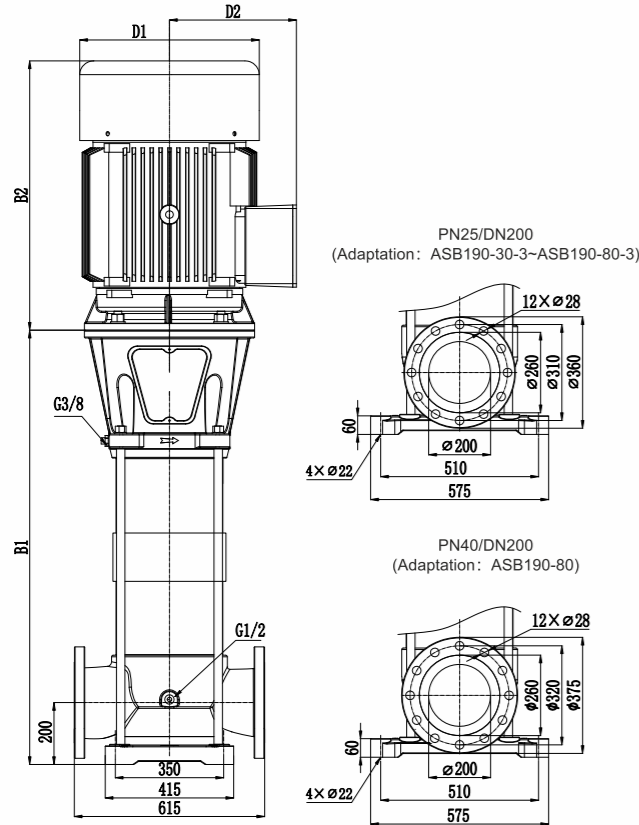

Model	Dimension(mm)					Weight (kg)
	B1	B2	B1+B2	D1	D2	
ASB190-30-3	1285	785	2070	484	365	629
ASB190-30	1285	849	2134	548	388	743
ASB190-40-3	1413	849	2262	548	388	755
ASB190-40	1413	900	2313	548	388	801
ASB190-50-3	1541	1190	2731	630	525	1144
ASB190-50	1541	1190	2731	630	525	1146
ASB190-60-3	1669	1190	2859	630	525	1298
ASB190-60	1669	1190	2859	630	525	1300
ASB190-70-3	1797	1190	2987	630	525	1300
ASB190-70	1797	1190	2987	630	525	1302
ASB190-80-3	1925	1190	3115	630	525	1584
ASB190-80	1925	1190	3115	630	525	1586

Performance data

Model	Power(kW)	Q (m³/h)	H (m)																			
			90	120	140	160	180	190	200	220	240											
ASB190-30-3	55		113	109	104	98	88	82	76	64	51											
ASB190-30	75		124	121	118	114	105	100	95	82	71											
ASB190-40-3	75		154	149	143	136	123	115	108	91	75											
ASB190-40	90		165	161	157	152	140	133	127	109	95											
ASB190-50-3	110		196	189	183	174	158	149	139	118	98											
ASB190-50	110		207	202	197	190	175	167	158	137	118											
ASB190-60-3	132		237	230	222	212	193	182	171	146	122											
ASB190-60	132		248	242	236	228	210	200	190	164	142											
ASB190-70-3	160		278	270	261	250	228	215	203	173	146											
ASB190-70	160		289	282	275	266	245	233	222	191	166											
ASB190-80-3	200		320	310	301	288	263	249	234	200	169											
ASB190-80	200		331	323	315	304	280	267	253	219	189											

Performance curve

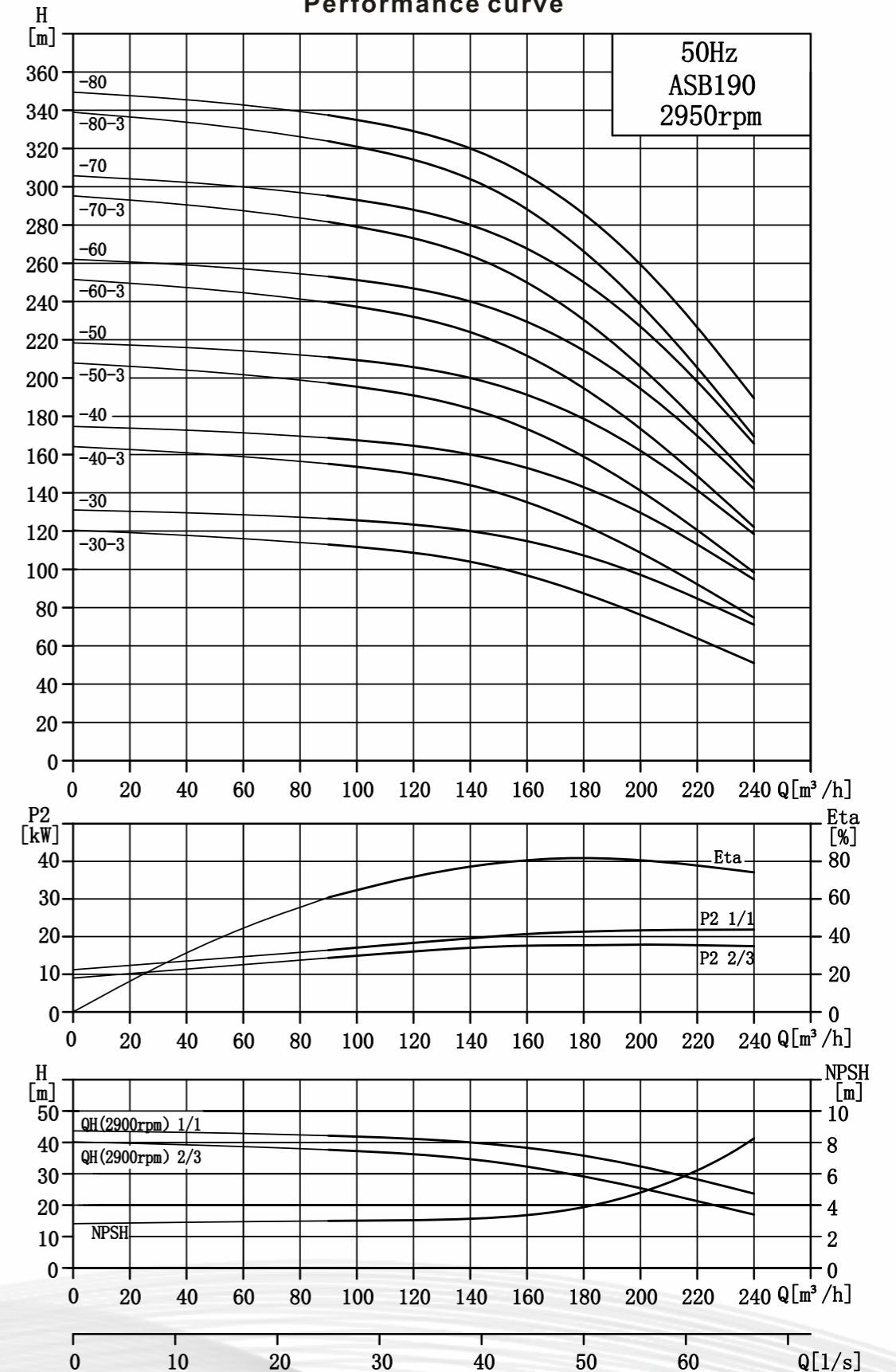

Installation dimensions and weight

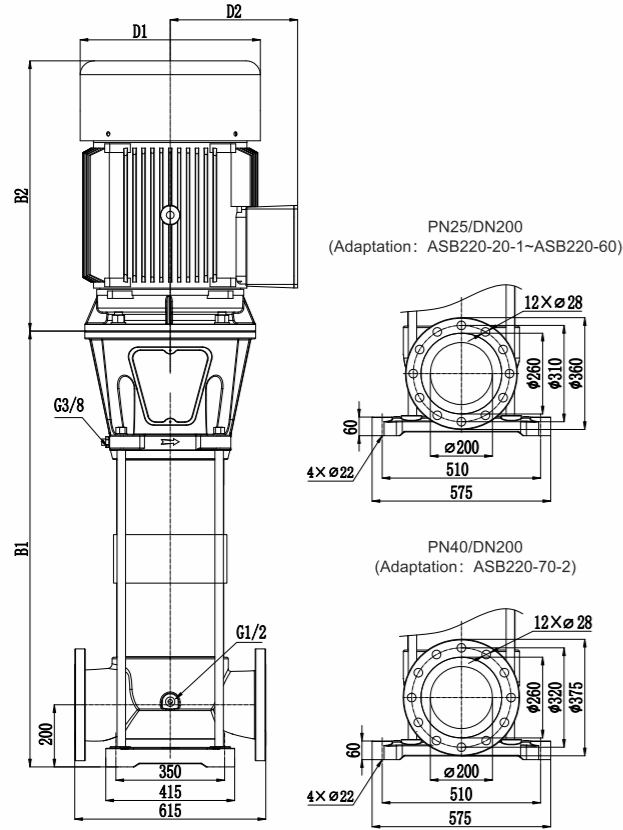

Model	Dimension(mm)					Weight (kg)
	B1	B2	B1+B2	D1	D2	
ASB220-20-1	1157	785	1942	484	365	626
ASB220-20	1157	849	2006	548	388	742
ASB220-30-2	1285	849	2134	548	388	752
ASB220-30	1285	900	2185	548	388	799
ASB220-40-2	1413	1190	2603	630	525	1136
ASB220-40	1413	1190	2603	630	525	1278
ASB220-50-2	1541	1190	2731	630	525	1281
ASB220-50	1541	1190	2731	630	525	1275
ASB220-60-3	1669	1190	2859	630	525	1281
ASB220-60	1669	1190	2859	630	525	1551
ASB220-70-2	1797	1190	2987	630	525	1559

Performance data

Model	Power(kW)	Q (m³/h)	H (m)											
			105	120	140	160	180	200	220	240	260	280	282	
ASB220-20-1	55	90	89	86	83	79	73	67	60	53	45	44		
ASB220-20	75	102	101	98	95	91	87	80	73	66	58	57		
ASB220-30-2	75	129	127	123	118	112	103	94	84	73	60	59		
ASB220-30	90	153	151	147	143	137	130	120	110	99	87	85		
ASB220-40-2	110	180	177	172	165	157	147	134	121	106	89	87		
ASB220-40	132	204	201	196	191	183	173	160	147	132	116	113		
ASB220-50-2	132	231	228	221	213	203	190	174	157	139	118	116		
ASB220-50	160	255	252	245	238	228	217	200	183	165	145	142		
ASB220-60-3	160	270	266	258	248	236	220	201	181	159	134	131		
ASB220-60	200	306	302	294	286	274	260	240	220	198	174	170		
ASB220-70-2	200	333	328	319	308	294	277	254	231	205	176	172		

Performance curve

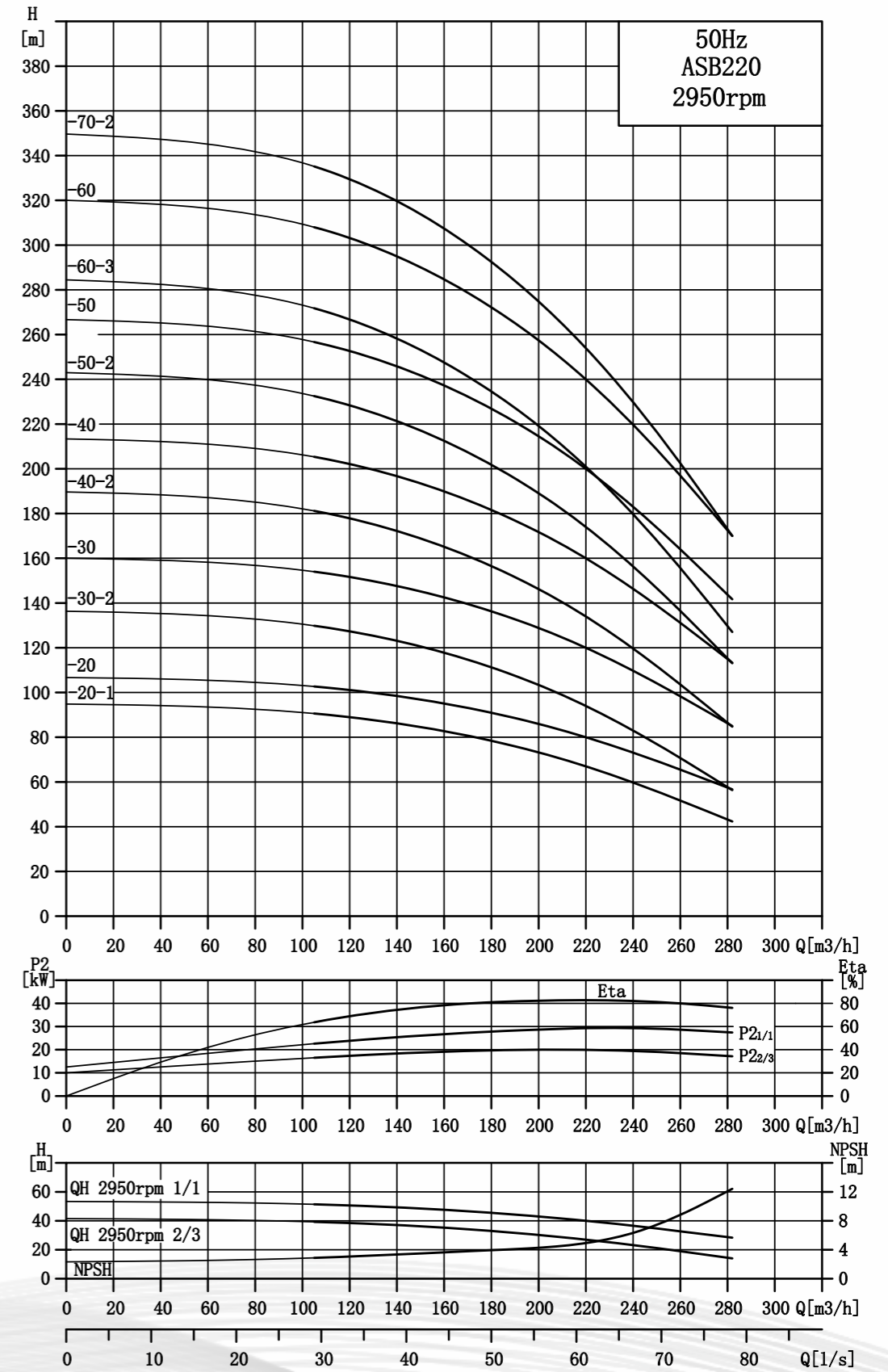

Installation dimensions and weight

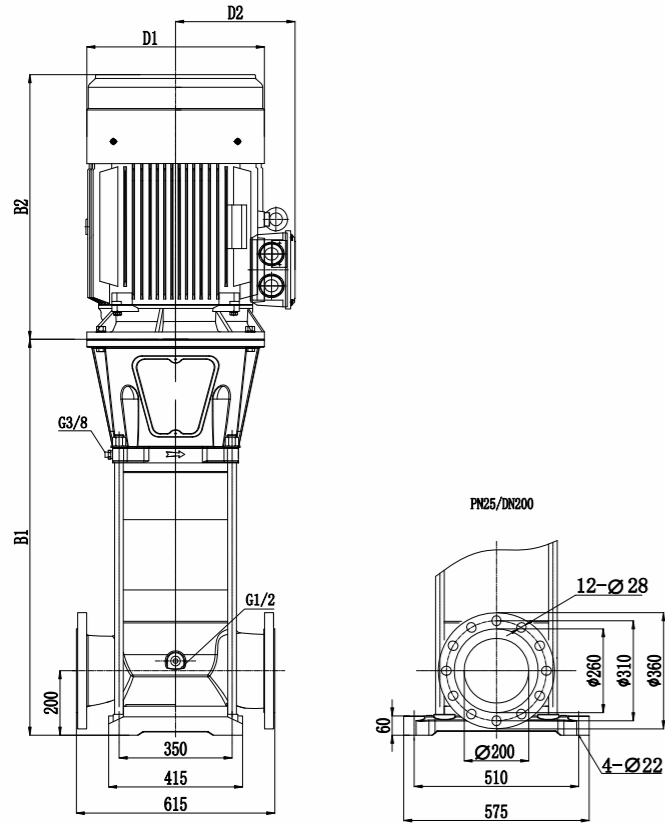

Model	Dimension(mm)					Weight (kg)
	B1	B2	B1+B2	D1	D2	
ASB260-20-2	1166	785	1951	484	365	618
ASB260-20	1166	849	2015	548	388	733
ASB260-30-2	1299	900	2199	548	388	784
ASB260-30	1299	1190	2489	630	525	1116
ASB260-40-2	1432	1190	2622	630	525	1261
ASB260-40	1432	1190	2622	630	525	1255
ASB260-50-3	1565	1190	2755	630	525	1261
ASB260-50	1565	1190	2755	630	525	1531
ASB260-60-2	1698	1190	2888	630	525	1536

Performance data

Model	Power(kW)	Q (m³/h)	H (m)												
			125	140	160	180	200	220	240	260	280	300	320	330	
ASB260-20-2	55		81	80	79	78	75	69	63	57	51	42.5	35	30.5	
ASB260-20	75		97	96	95	94	93	91	86	81	74	67	59	55	
ASB260-30-2	90		130	128	126	124	121	115	106	98	88	76	64	58	
ASB260-30	110		145	144	143	142	140	136	129	121	111	100	89	82	
ASB260-40-2	132		178	177	175	173	168	160	150	138	125	109	94	85	
ASB260-40	160		194	193	192	190	186	182	172	161	148	133	118	110	
ASB260-50-3	160		199	217	214	211	205	195	181	167	150	130	111	101	
ASB260-50	200		242	241	239	237	233	227	215	202	185	167	148	137	
ASB260-60-2	200		274	272	270	267	261	251	236	219	199	176	153	140	

Performance curve

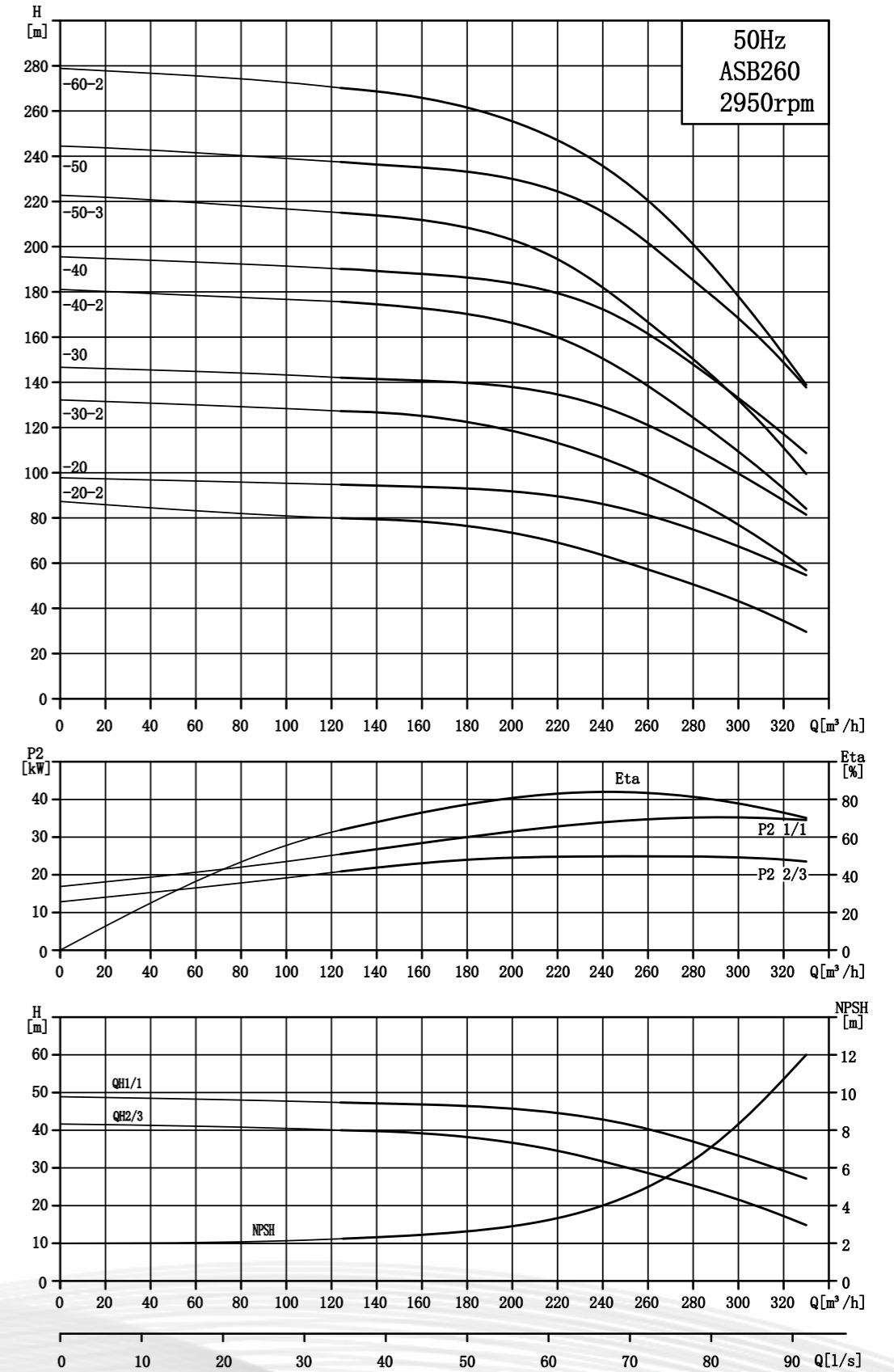

Installation dimensions and weight

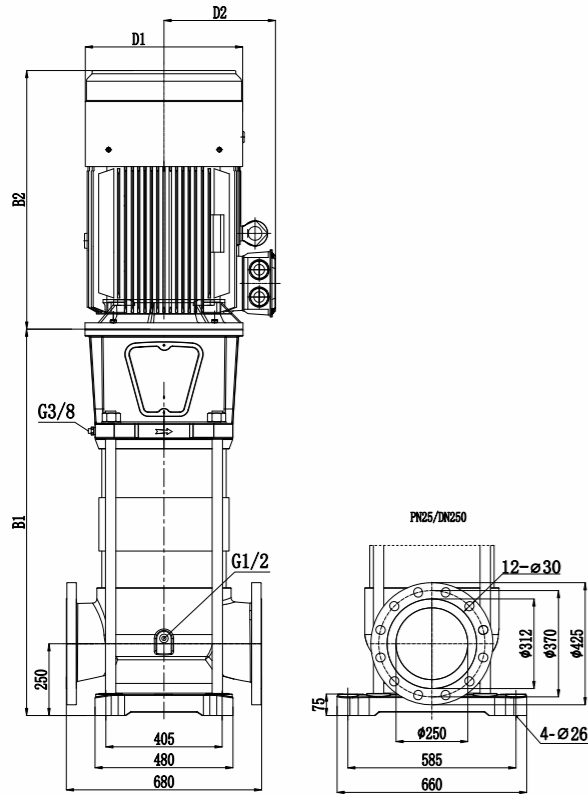

Model	Dimension(mm)					Weight (kg)
	B1	B2	B1+B2	D1	D2	
ASB300-20-2A	1334	785	2119	448	365	599
ASB300-20-2	1334	849	2183	548	388	737
ASB300-20	1334	900	2234	548	388	784
ASB300-30-3	1479	1190	2669	630	525	1106
ASB300-30	1479	1190	2669	630	525	1261
ASB300-40-2	1624	1190	2814	630	525	1258
ASB300-40	1624	1190	2814	630	525	1483
ASB300-50-1-1A	1769	1190	2959	630	525	1534
ASB300-50	1769	1190	2959	630	525	1535

Performance data

Model	Power(kW)	Q (m³/h)	H (m)													
			160	180	200	220	240	260	280	300	320	340	360	380	400	
ASB300-20-2A	55		78	76	73	70	66	62	57	52	46	40	40	26	18	
ASB300-20-2	75		95	93	90	87	83	79	75	70	65	59	59	47	40	
ASB300-20	90		104	103	101	99	96	93	90	85	80	75	75	62	55	
ASB300-30-3	110		145	141	137	133	127	122	115	107	100	92	92	72	62	
ASB300-30	132		157	155	152	149	145	141	135	129	122	114	114	95	85	
ASB300-40-2	160		195	192	188	183	177	170	163	155	145	135	135	110	95	
ASB300-40	185		209	206	203	200	195	190	183	174	166	156	156	131	115	
ASB300-50-1-1A	200		243	238	232	225	218	210	200	189	178	165	165	133	114	
ASB300-50	220		261	257	253	248	243	235	227	219	208	195	195	164	144	

Performance curve

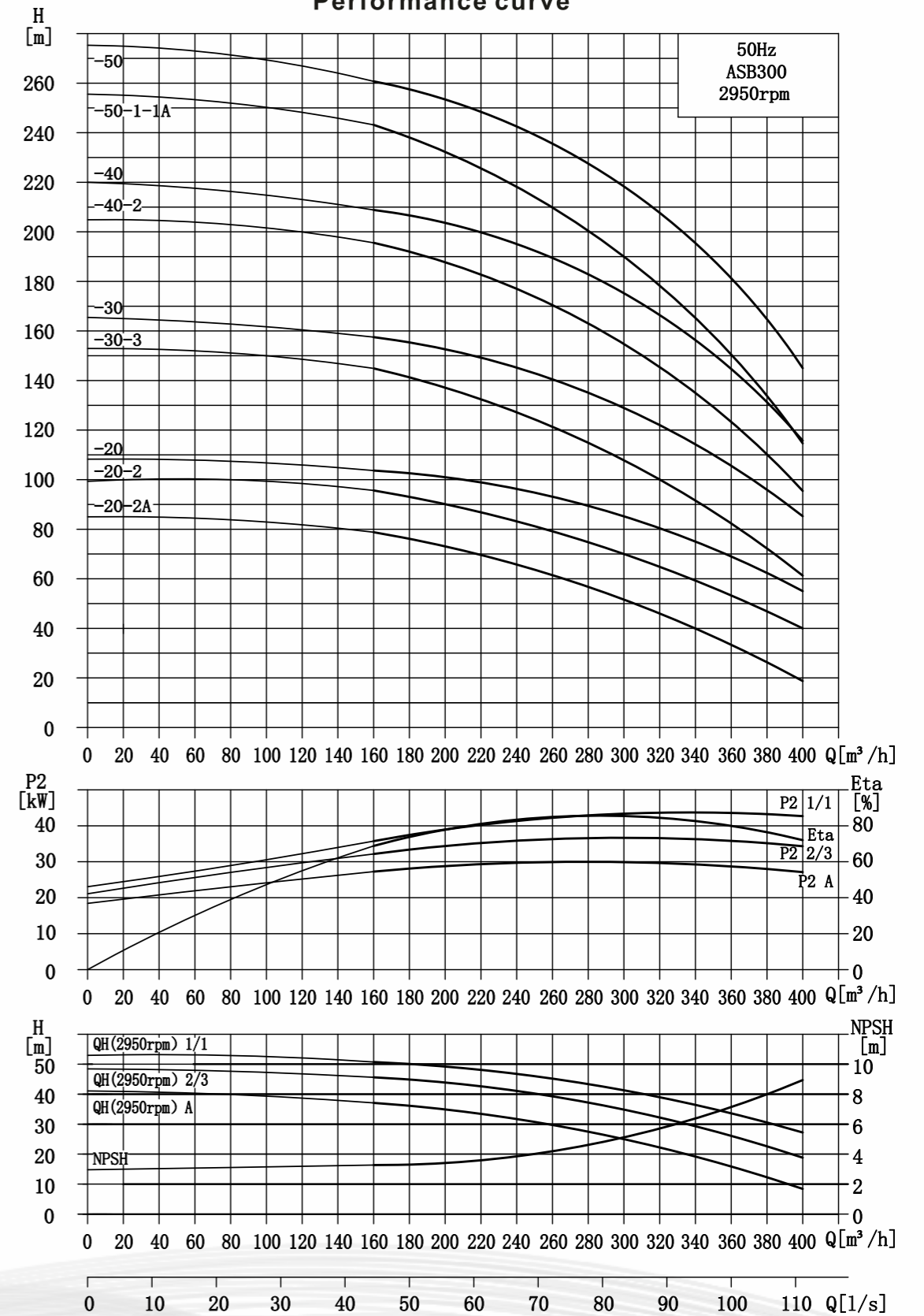

Installation dimensions and weight

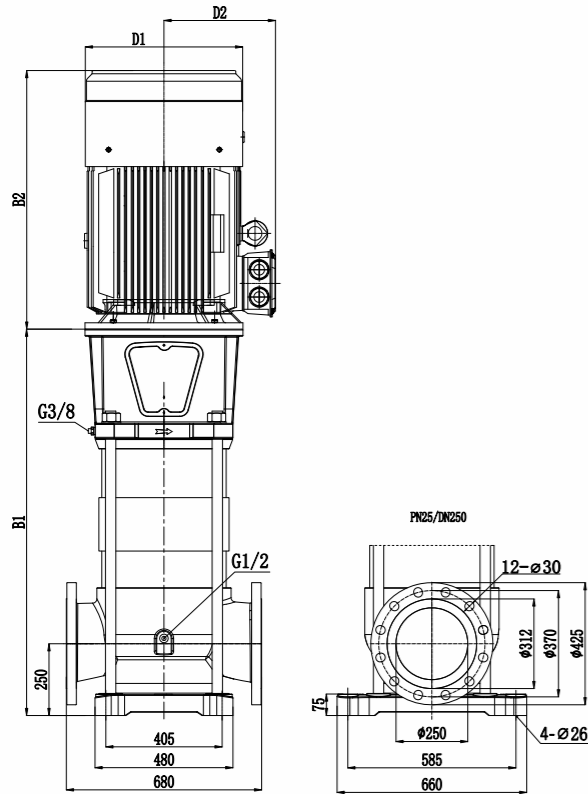

Model	Dimension(mm)					Weight (kg)
	B1	B2	B1+B2	D1	D2	
ASB350-20-2A	1334	849	2183	548	388	739
ASB350-20-2	1334	900	2234	548	388	786
ASB350-20	1334	1190	2524	630	525	1105
ASB350-30-3	1479	1190	2669	630	525	1259
ASB350-30	1479	1190	2669	630	525	1253
ASB350-40-2A	1624	1190	2814	630	525	1485
ASB350-40-2	1624	1190	2814	630	525	1530
ASB350-40	1624	1190	2814	630	525	1576

Performance data

Model	Power(kW)	Q (m³/h)	H (m)													
			180	200	220	240	260	280	300	320	340	360	380	400	420	
ASB350-20-2A	75		88	86	94	81	78	75	71	67	63	60	52	45	38	
ASB350-20-2	90		96	94	92	90	88	85	82	78	74	72	63	57	51	
ASB350-20	110		113	11	110	108	106	103	100	96	93	90	83	74	71	
ASB350-30-3	132		146	144	141	138	135	130	125	120	113	110	98	90	80	
ASB350-30	160		173	171	168	165	162	158	154	148	142	138	127	118	110	
ASB350-40-2A	185		202	198	195	190	185	178	172	164	156	150	135	124	110	
ASB350-40-2	200		211	207	203	198	193	190	184	173	167	163	147	136	125	
ASB350-40	220		231	228	224	221	216	211	205	198	190	186	171	160	147	

Performance curve

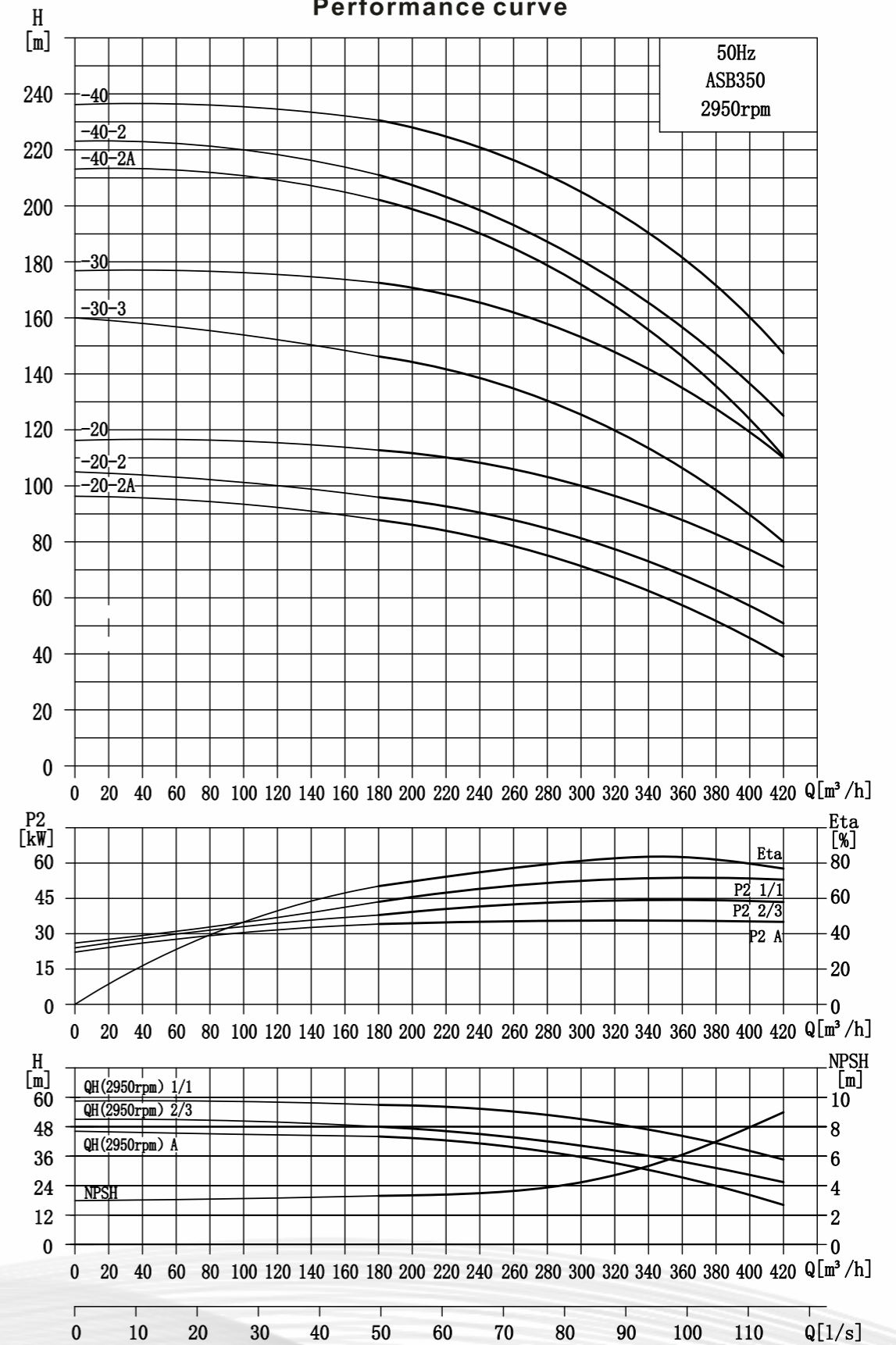

Installation dimensions and weight

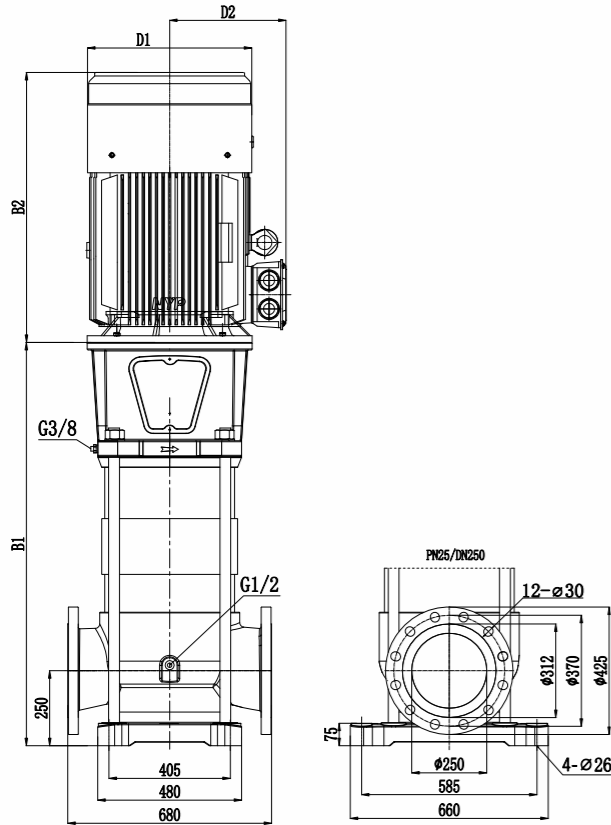

Model	Dimension(mm)					Weight (kg)
	B1	B2	B1+B2	D1	D2	
ASB400-20-2A	1304	704	2008	442	324	572
ASB400-20-2	1304	704	2008	442	324	598
ASB400-20	1304	704	2008	442	324	615
ASB400-30-3A	1449	704	2153	442	324	644
ASB400-30-3	1479	785	2264	484	365	671
ASB400-30-2	1479	785	2264	484	365	700
ASB400-30	1479	785	2264	484	365	720
ASB400-40-2A	1624	785	2409	484	365	741
ASB400-40-1	1624	929	2553	548	388	815

Performance data

Model	Power(kW)	Q (m³/h)	H (m)													
			216	240	270	300	330	360	390	400	420	450	480	498		
ASB400-20-2A	132		124	122	120	115	110	104	96	93	87	77	66	57		
ASB400-20-2	160		140	137	133	129	124	118	112	108	103	94	85	77		
ASB400-20	185		158	156	153	149	145	140	134	132	127	120	111	105		
ASB400-30-3A	200		190	187	182	175	167	157	146	142	134	129	102	88		
ASB400-30-3	225		210	206	201	194	187	178	168	164	157	143	130	118		
ASB400-30-2	250		221	216	211	204	196	188	178	175	168	155	142	131		
ASB400-30	280		239	237	232	226	220	212	204	200	194	182	169	160		
ASB400-40-2A	315		284	280	273	264	255	244	232	227	217	200	180	164		
ASB400-40-1	355		310	305	299	291	282	271	260	255	246	230	213	199		

Performance curve

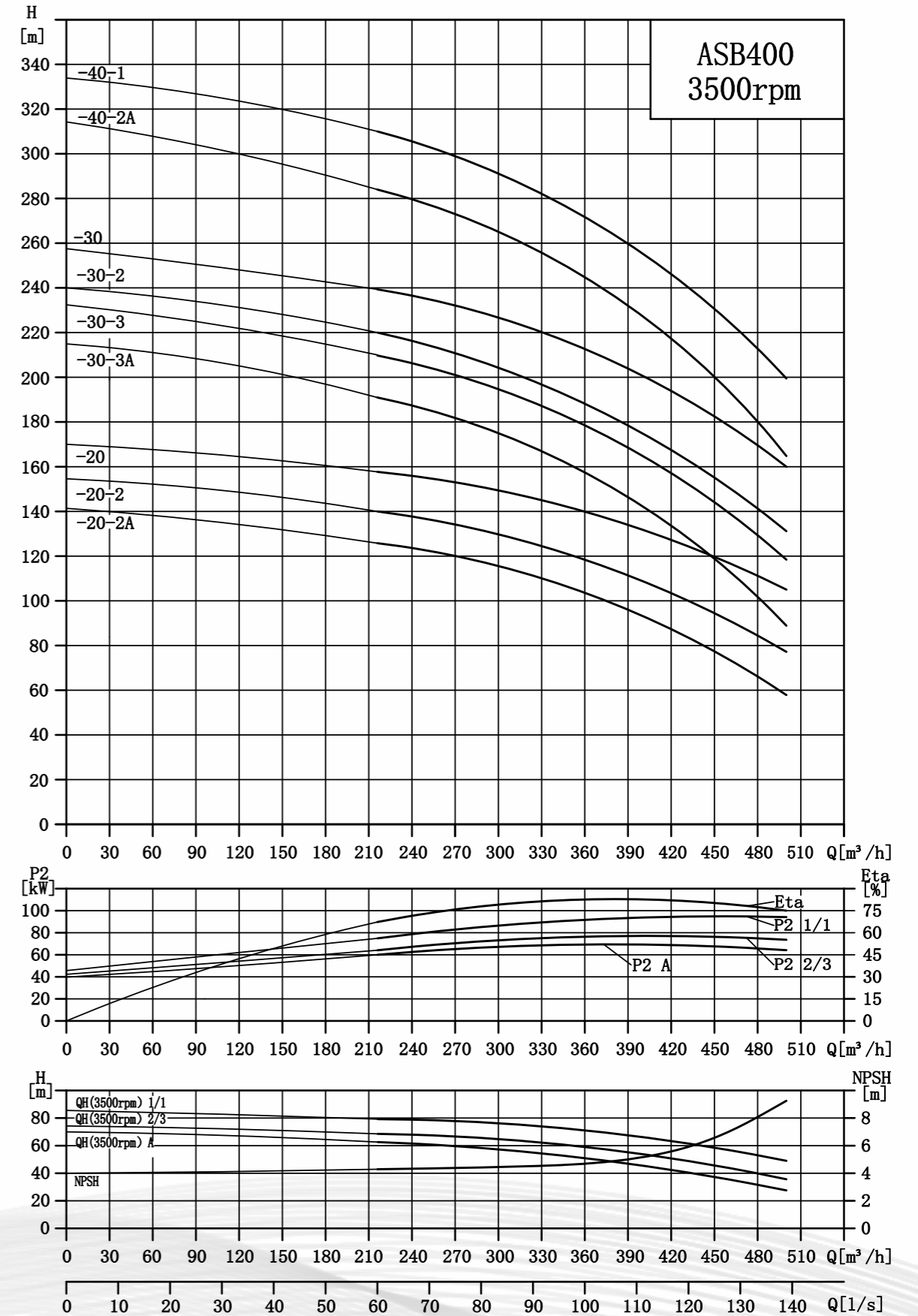

Installation dimensions and weight

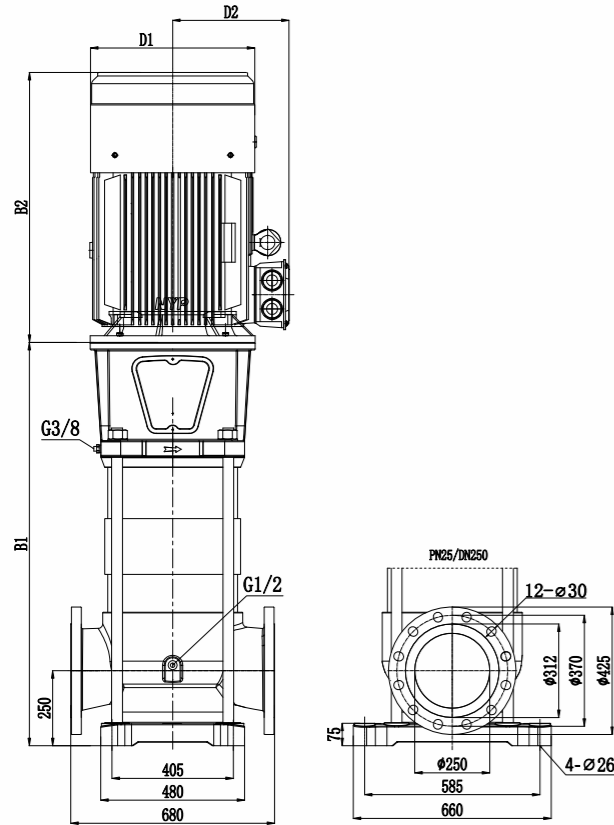

Model	Dimension(mm)					Weight (kg)
	B1	B2	B1+B2	D1	D2	
ASB450-20-2A	1304	704	2008	442	324	572
ASB450-20-2	1304	704	2008	442	324	598
ASB450-20	1304	704	2008	442	324	615
ASB450-30-3A	1449	704	2153	442	324	644
ASB450-30-3	1479	785	2264	484	365	671
ASB450-30-2	1479	785	2264	484	365	700
ASB450-30	1479	785	2264	484	365	720
ASB450-40-2A	1624	785	2409	484	365	741
ASB450-40-1	1624	929	2553	548	388	815

Performance data

Model	Power(kW)	Q (m³/h)	H (m)													
			216	240	270	300	330	360	390	400	420	450	480	498		
ASB450-20-2A	132		124	122	120	115	110	104	96	93	87	77	66	57		
ASB450-20-2	160		140	137	133	129	124	118	112	108	103	94	85	77		
ASB450-20	185		158	156	153	149	145	140	134	132	127	120	111	105		
ASB450-30-3A	200		190	187	182	175	167	157	146	142	134	129	102	88		
ASB450-30-3	225		210	206	201	194	187	178	168	164	157	143	130	118		
ASB450-30-2	250		221	216	211	204	196	188	178	175	168	155	142	131		
ASB450-30	280		239	237	232	226	220	212	204	200	194	182	169	160		
ASB450-40-2A	315		284	280	273	264	255	244	232	227	217	200	180	164		
ASB450-40-1	355		310	305	299	291	282	271	260	255	246	230	213	199		

Performance curve

